

FAN COILS, and ACCESSORY ELECTRIC HEATERS

WIRING DIAGRAMS

NOTE: Read the entire instruction manual before starting the installation

FIG.	FIELD-INSTALLED HEATER MODEL	FB4C/PF4MNP	FE4A/FE5A	FH4C	FV4C	FX4D	FY5B	FZ4A	PF4MA	PF4MB	LABEL
Fig. 1	KFCEH0401N03B	18,24	x	001	x	19,25	18,24	24	18,19,24,25	x	344631-101
Fig. 1	KFCEH0501N05B	18-60	002-006	001-002	002-006	19-61	18-60	24-61	18-61	19-61	344631-101
Fig. 2	KFCEH0801N08B	18-60	002-006	001-003	002-006	19-61	18-60	24-61	18-61	19-61	344599-101
Fig. 2	KFCEH0901N10B	18-60	002-006	001-004	002-006	19-61	18-60	24-61	18-61	19-61	344599-101
Fig. 6	KFCEH1601315B	42-60	002-006	001-004	002-006	43-61	18-60	48-61	18-61	19-61	344635-101
Fig. 7	KFCEH2001318B	42-60	003-006	001-004	002-006	43-61	42-60	48-61	42-61	37-61	344654-101
Fig. 1	KFCEH2401C05B	18-60	002-006	001-002	002-006	19-61	18-60	24-61	18-61	19-61	344631-101
Fig. 2	KFCEH2501C08B	18-60	002-006	001-003	002-006	19-61	18-60	24-61	18-61	19-61	344599-101
Fig. 2	KFCEH2601C10B	18-60	002-006	001-004	002-006	19-61	18-60	24-61	18-61	19-61	344599-101
Fig. 3	KFCEH2901N09B	36-60	002-006	003-004	002-006	37-61	36-60	36-61	36-60	31-61	344634-101
Fig. 4	KFCEH3001F15B	24-60	002-006	001-004	002-006	25-61	24-60	24-61	24-61	19-61	344597-101
Fig. 4	KFCEH3101C15B	24-60	002-006	001-004	002-006	25-61	24-60	24-61	24-61	19-61	344597-101
Fig. 5	KFCEH3201F20B	30-60	002-006	002-004	002-006	31-61	30-60	36-61	30-61	19-61	345611-101
Fig. 5	KFCEH3301C20B	30-60	002-006	002-004	002-006	31-61	30-60	36-61	30-61	19-61	345611-101
Fig. 8 Fig. 9	KFCEH3401F24B	48,60	004-006	003-004	005-006	49-61	48-60	48-61	48-61	49-61	345655-101 345656-101
Fig. 8 Fig. 9	KFCEH3501F30B	48,60	004-006	003-004	005-006	49-61	48-60	48-61	48-61	49-61	345655-101 345656-101

FAN COIL WITH RBC X-13 MOTOR OR BROAD OCEAN DIGI MOTOR

FIG.	FACTORY-INSTALLED HEATER MODEL	FB4C	FX4D	FZ4A	LABEL
Fig. 11	MKFCEH0501N05B	18,24	19,25	--	344637-101
Fig. 10	MKFCEH0801N08B	18,30	31	--	344624-101
Fig. 10	MKFCEH0901N10B	24-48	37-61	--	
Fig. 12	MKFCEH1501F15B	36-60	61	--	344623-101
Fig. 32	MKFCEH0501N05B	--	--	24	344771-101
Fig. 30	MKFCEH0801N08B	--	--	36,48	344772-101
	MKFCEH0901N10B	--	--		
Fig. 31	MKFCEH1501F15B	--	--	60,61	344773-101

FAN COIL WITH COOLING ONLY CONTROL

FIG.	MODEL	SIZE	LABEL
Fig. 13	FV4C	002-006	326014-101
Fig. 14	FE4A / FE5A	002-006	333107-101
Fig. 15	FY5B / PF4MNA	18-60	328964-101
Fig. 15	FH4C	001-004	328964-101
Fig. 16	FB4C / FX4D / PF4MNP (RBC)	18-61	336228-101
Fig. 16	PF4MNA/B	19,25,31,37,43,49,61	336228-101
Fig. 17	FB4C / FX4D / PF4MNP (BOM)	18-61	337519-101
Fig. 33	FZ4A	24-61	342415-101

50 HZ EXPORT FAN COILS

FIG.	MODEL	SIZE	LABEL
Fig. 34	FB4(C/Q)SL (Regal Beloit motor)	018-060	336228-101
Fig. 35	FB4(C/Q)SL (Broad Ocean motor)	018-060	337519-101

ELECTRIC HEATERS

FIG.	HEATER MODEL	FF1E	LABEL
Fig. 18	KFDEH0801D05A	18,24,30,36	341080-101
Fig. 19	KFDEH0901D75A	18,24,30,36	341081-101
Fig. 19	KFDEH1001D11A	18,24,30,36	341081-101
Fig. 20	KFEEH0101D05A	19,25,31,37	341082-101
Fig. 21	KFEEH0201D75A	19,25,31,37	341083-101
Fig. 21	KFEEH0301D11A	19,25,31,37	341083-101

FIG.	HEATER MODEL	CONTROL TYPE	FFMA / FMA4	LABEL
Fig. 22	EHK2-05B	Sequencer - HS	18,24,30,36 Prior to serial number date code 1715V.	202070290385
Fig. 22	EHK2-08B	Sequencer - HS	18,24,30,36 Prior to serial number date code 1715V.	202070290385
Fig. 22	EHK2-10B	Sequencer - HS	18,24,30,36 Prior to serial number date code 1715V.	202070290385
Fig. 23			18-37 Serial number date code 1715V and later.	2020702A717
Fig. 24	EHK205B	Relay - HR	18-37	06-7094-07
Fig. 24	EHK208B	Relay - HR	18-37	06-7094-07
Fig. 24	EHK210B	Relay - HR	18-37	06-7094-07

FIG.	FFMA	LABEL
Fig. 25	19,31	--
Fig. 26	25,37	--

FIG.	FPM(A,B)N(C,U)	LABEL
Fig. 27	ALL with Time Delay Relay	202070290388 Valid for models FPM(A,B)N(C,U)0**000AAAA
Fig. 28	ALL with Time Delay Board	2020702A1716 Valid for models FPM(A,B)N(C,U)T00ACAA

FIG.	HEATER MODEL	FPMAN(C,U)	FPMBN(C,U)	FMC4 / FMU4	LABEL
Fig. 29	EHK305B	18-36	18-30	18-36	06-7094-04
Fig. 29	EHK308B	18-36	18-30	18-36	06-7094-04
Fig. 29	EHK310B	18-36	18-30	18-36	06-7094-04

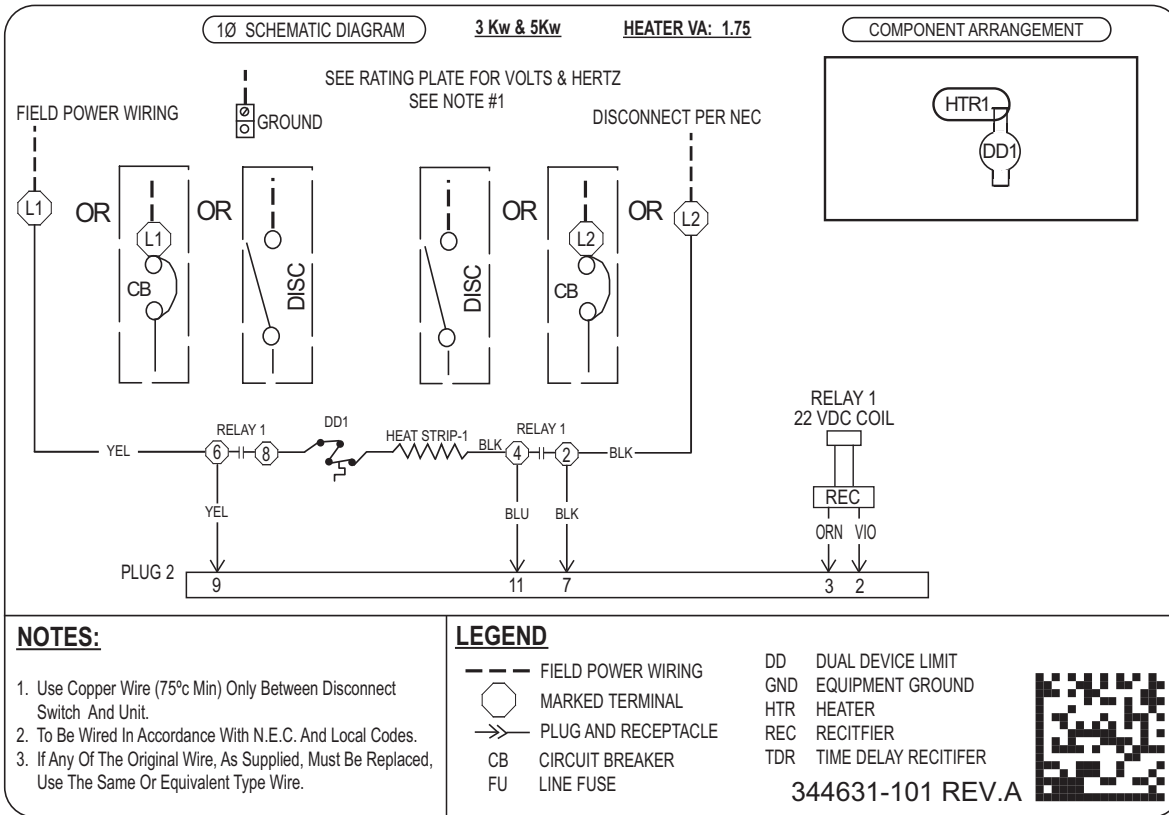

Fig. 1 – Heaters KFCEH0401N03B / KFCEH0501N05B / KFCEH2401C05B

A190003

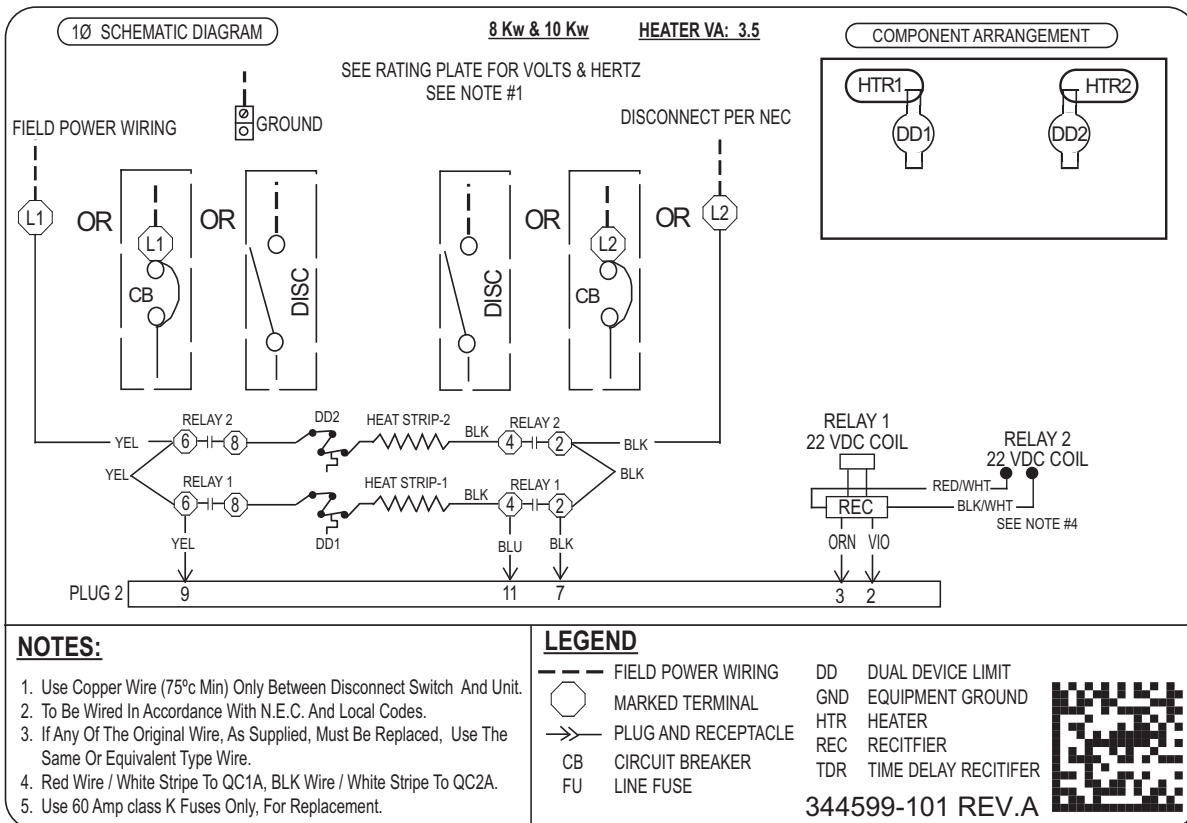

Fig. 2 – Heaters KFCEH0801N08B / KFCEH0901N10B / KFCEH2501C08B / KFCEH2601C10B

A190004

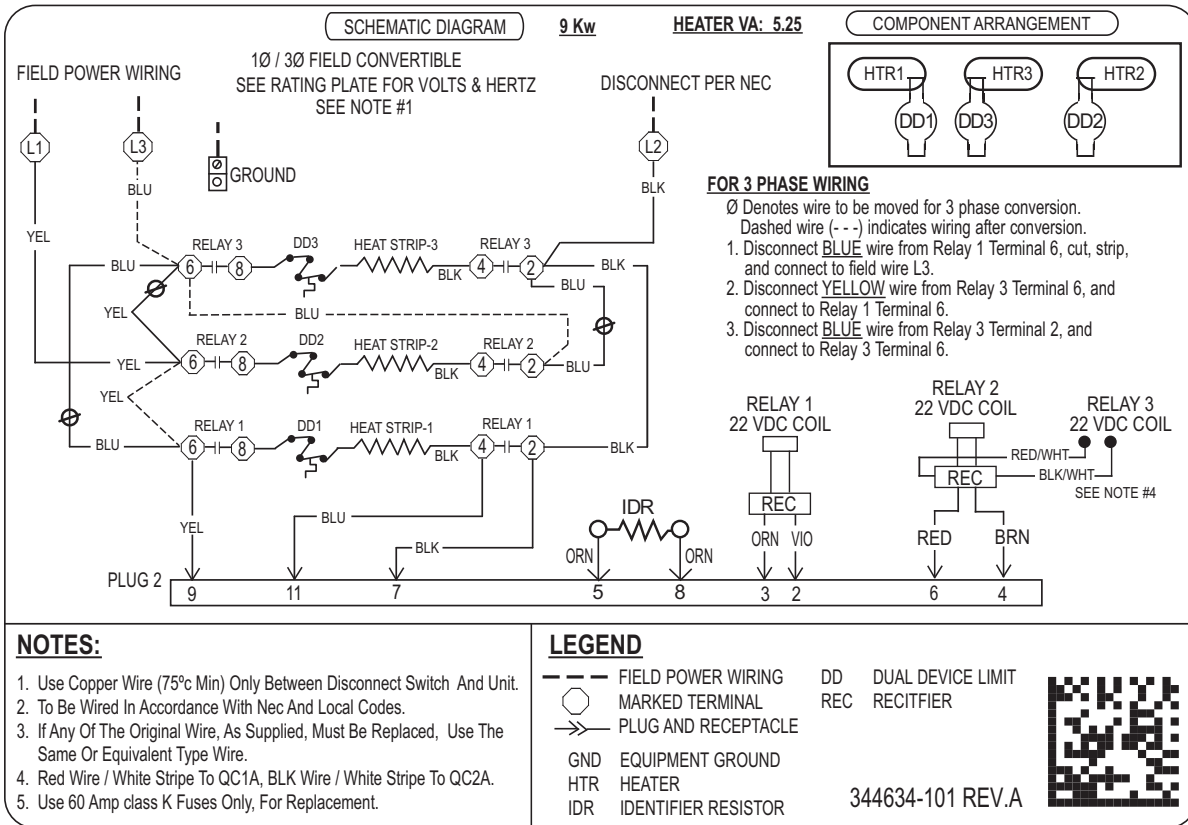

Fig. 3 – Heater KFCEH2901N09B

A190005

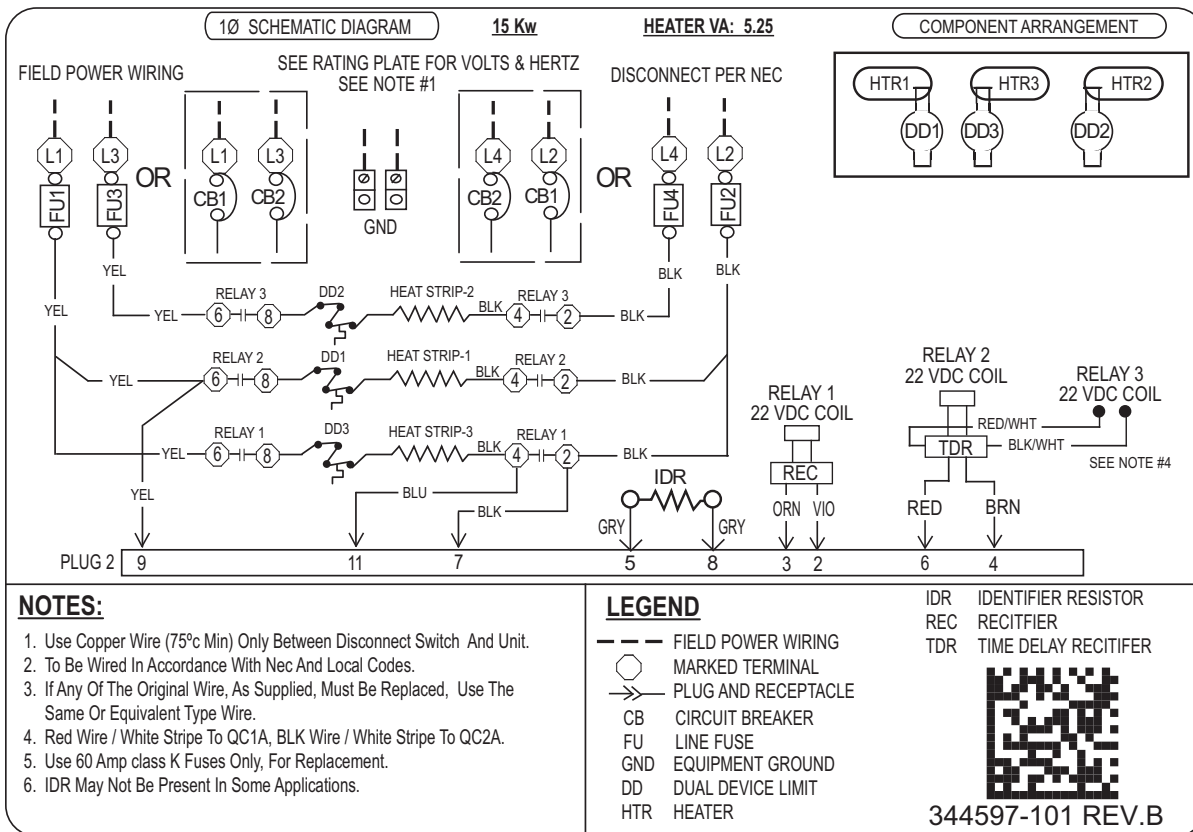

Fig. 4 – Heaters KFCEH3001F15B / FCEH3101C15B

A200124

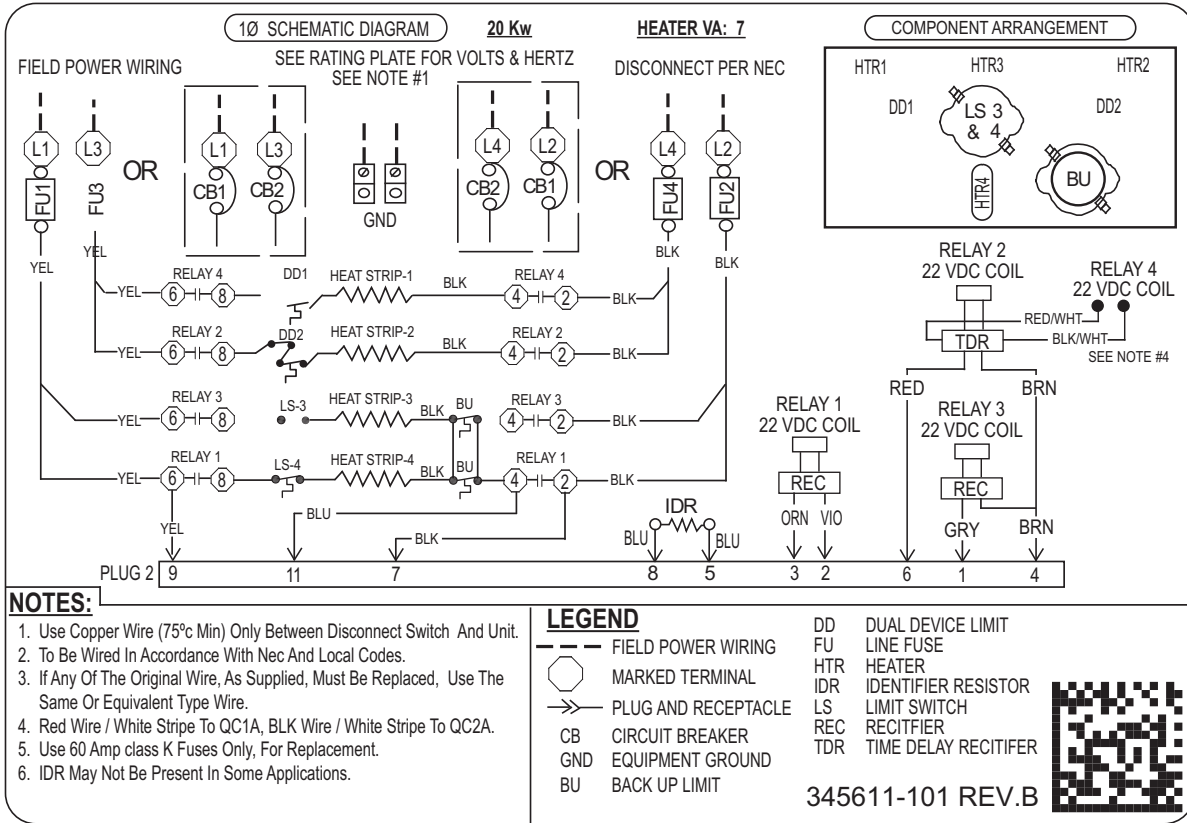

Fig. 5 – Heaters KFCEH3201F20B / KFCEH3301C20B

A20061

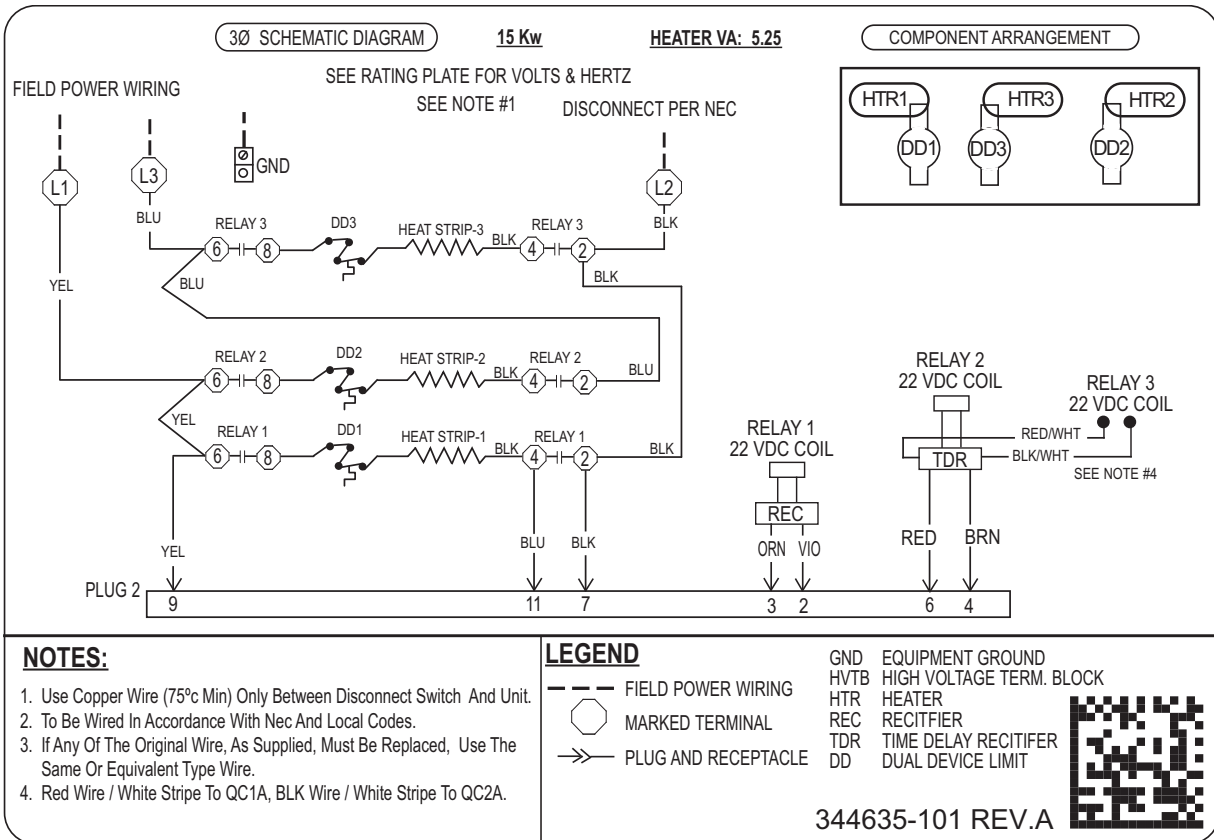

Fig. 6 – Heater KFCEH1601315B

A190008

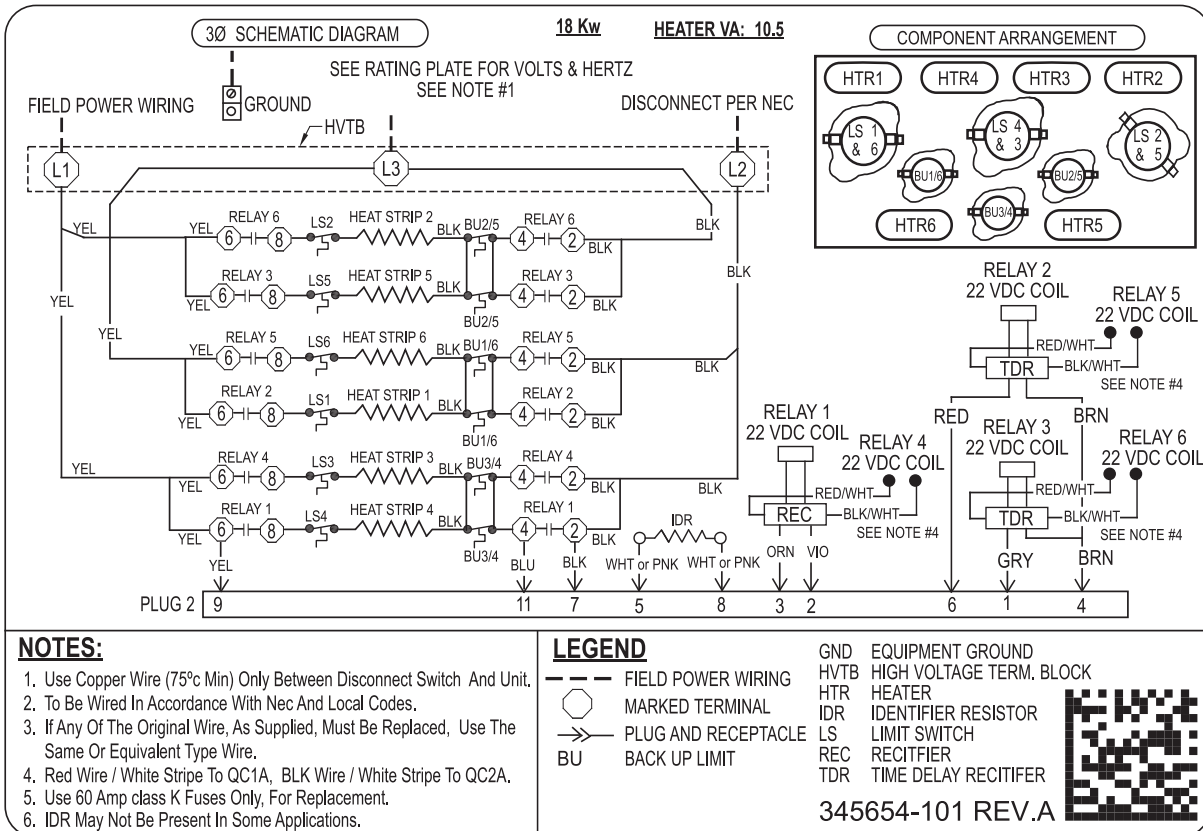

Fig. 7 – Heater KFCEH2001318B

A200060

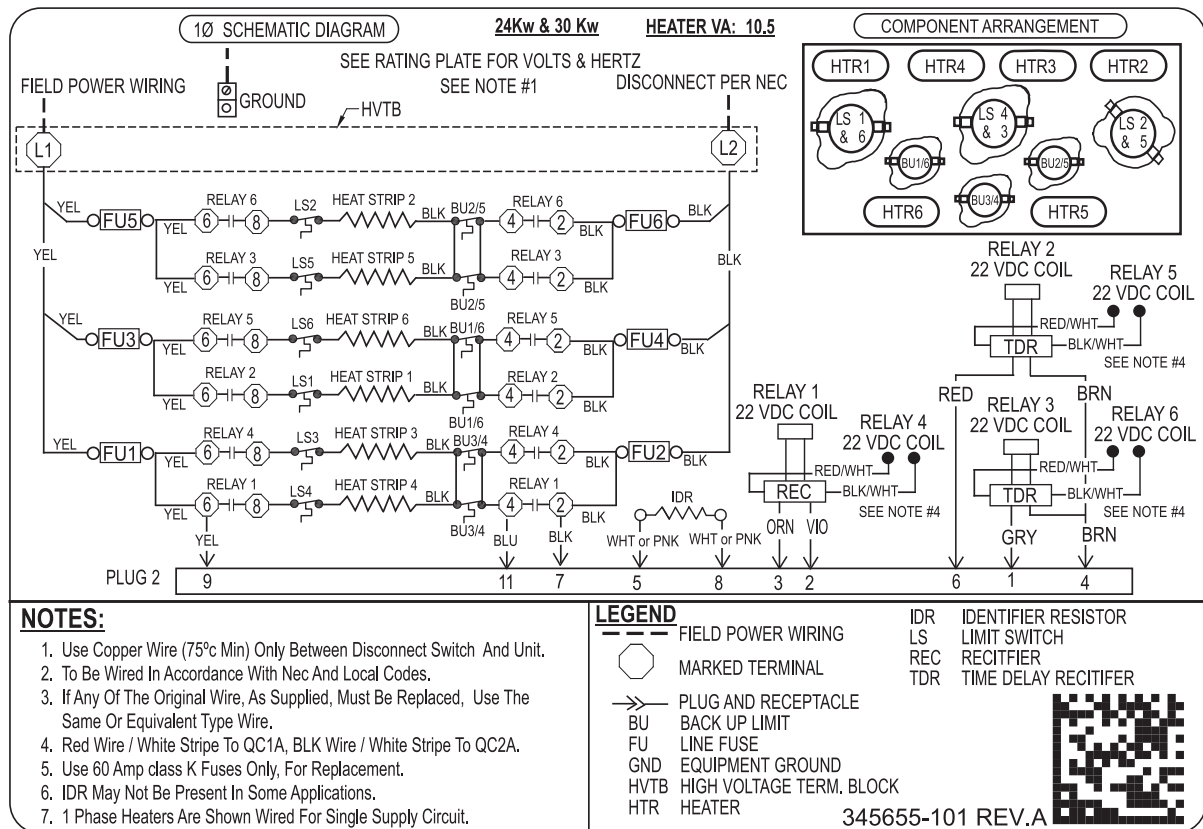

Fig. 8 – Heaters KFCEH3401F24B / KFCEH3501F30B (single phase)

A200062

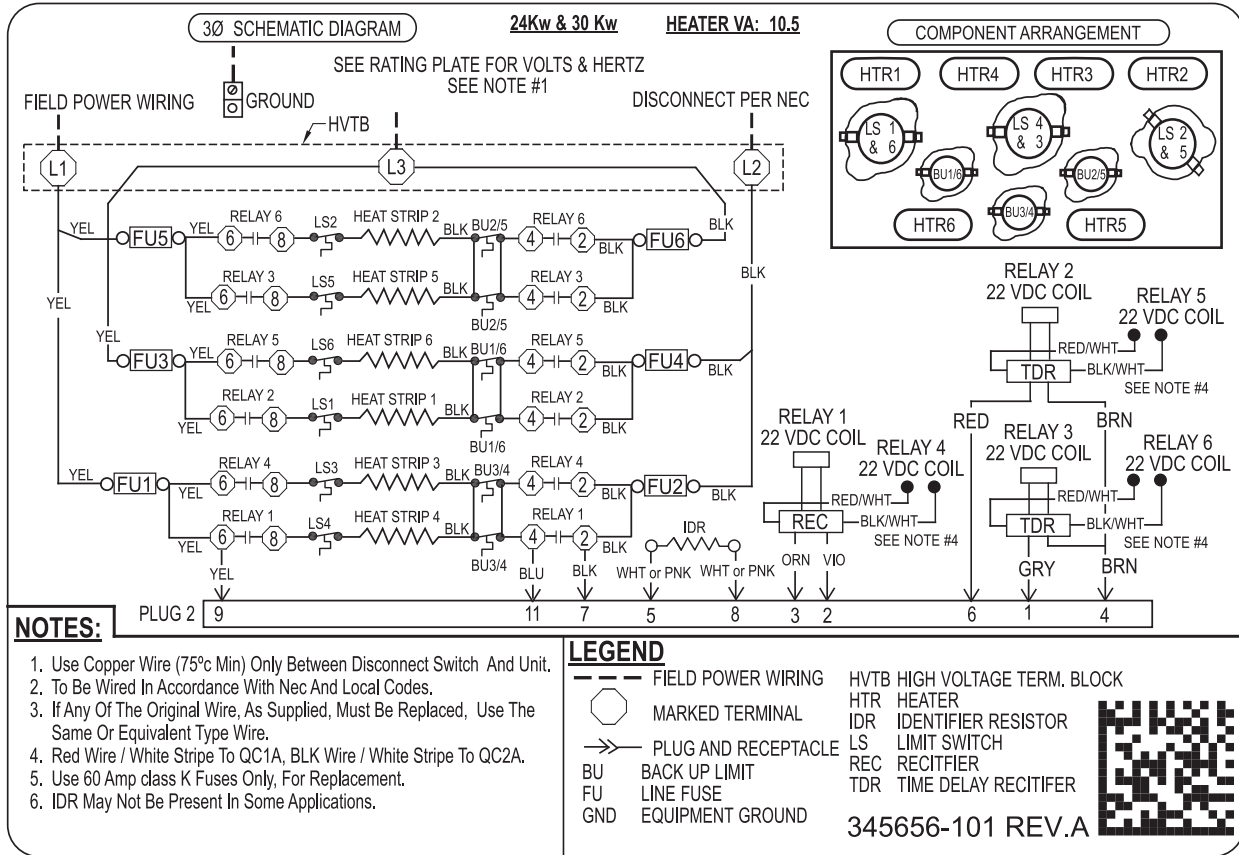
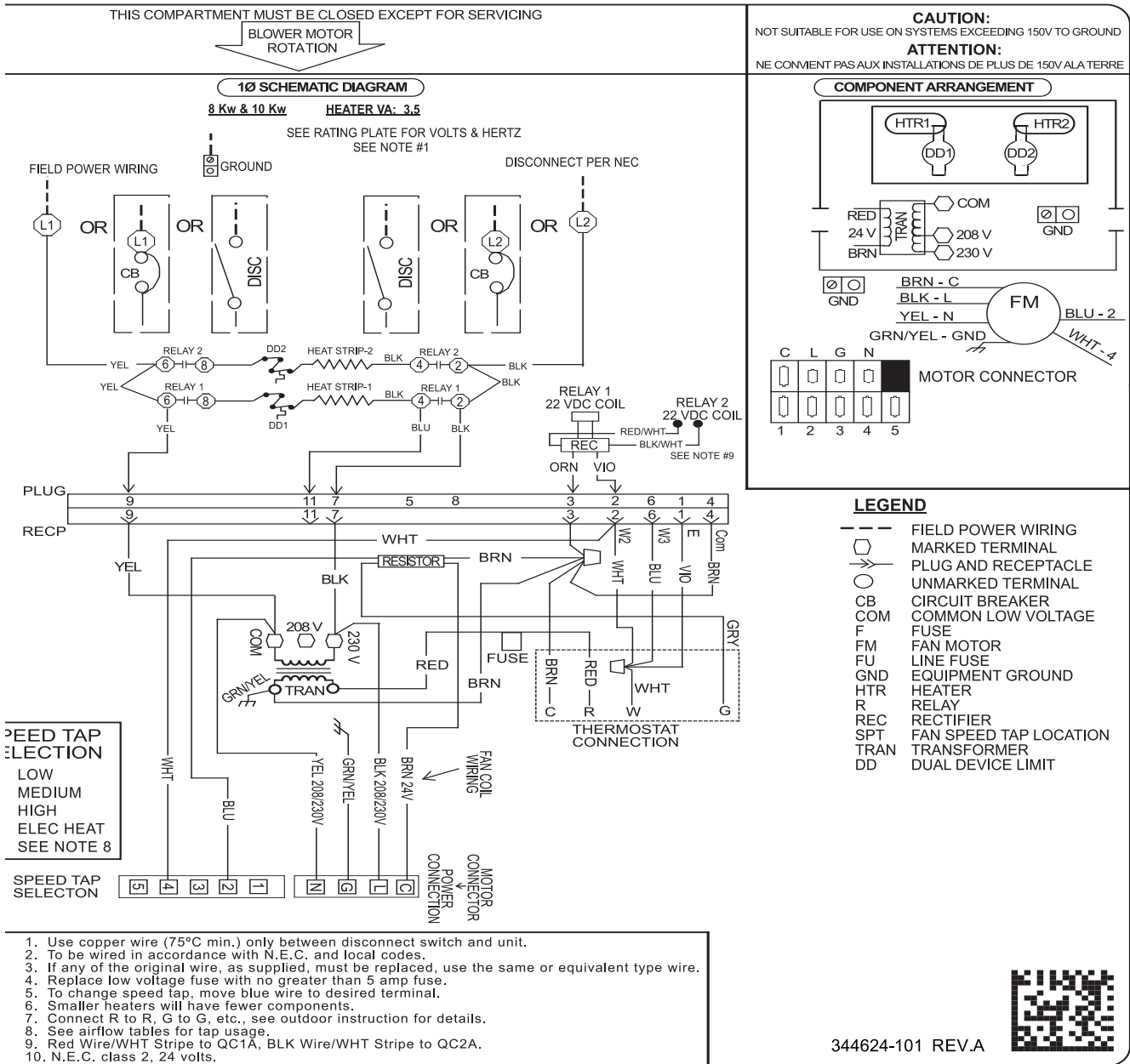

Fig. 9 – Heaters KFCEH3401F24B / KFCEH3501F30B (three phase)

A200063



1. Use copper wire (75°C min.) only between disconnect switch and unit.
2. To be wired in accordance with N.E.C. and local codes.
3. If any of the original wire, as supplied, must be replaced, use the same or equivalent type wire.
4. Replace low voltage fuse with no greater than 5 amp fuse.
5. To change speed tap, move blue wire to desired terminal.
6. Smaller heaters will have fewer components.
7. Connect R to R, G to G, etc., see outdoor instruction for details.
8. See airflow tables for tap usage.
9. Red Wire/WHT Stripe to QC1A, BLK Wire/WHT Stripe to QC2A.
10. N.E.C. class 2, 24 volts.



Fig. 10 – FB4C, FX4D - Heaters MKFCEH0801N08B / MKFCEH0901N10B

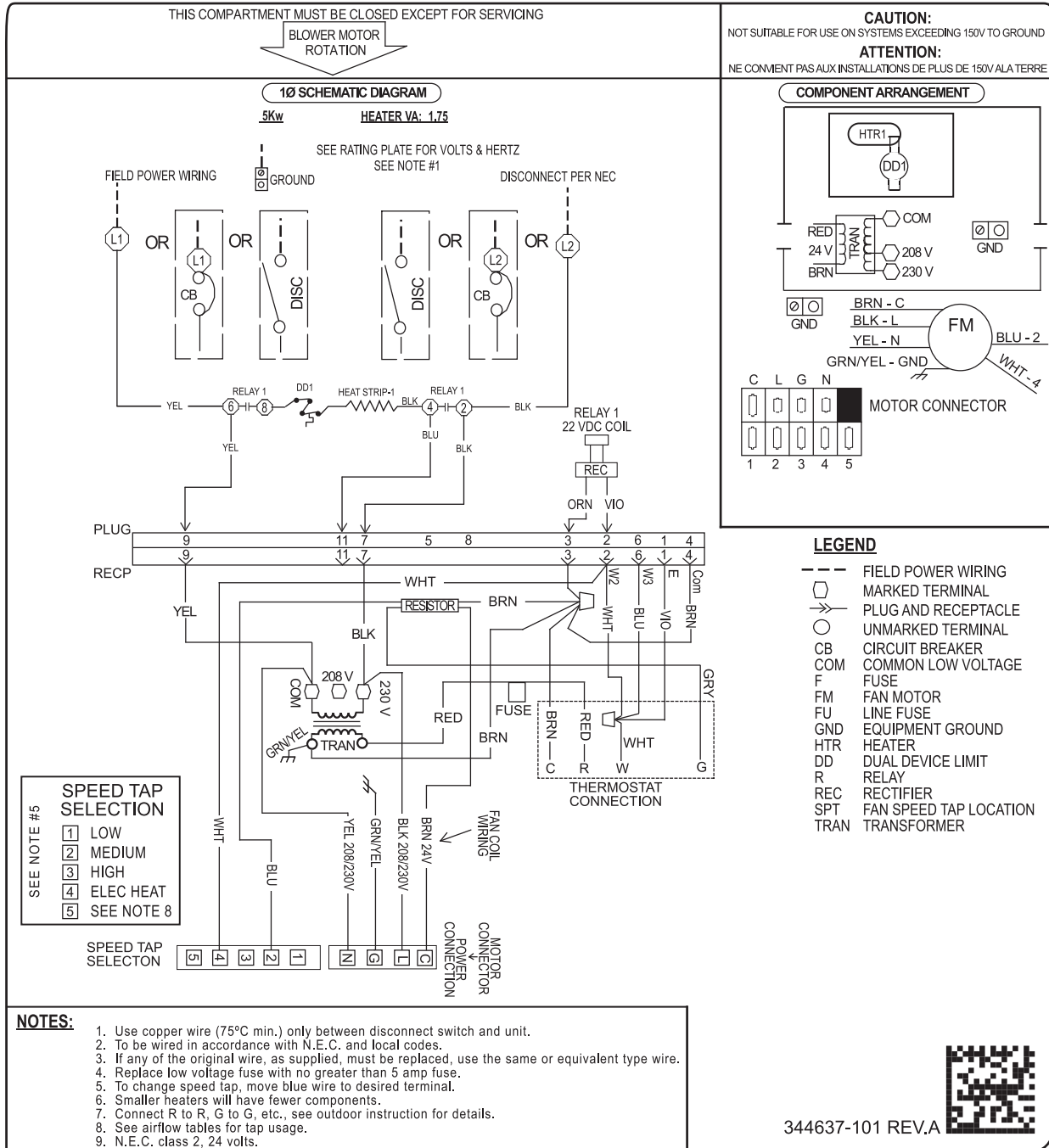

Fig. 11 – FB4C, FX4D - Heater MKFCEH0501N05B

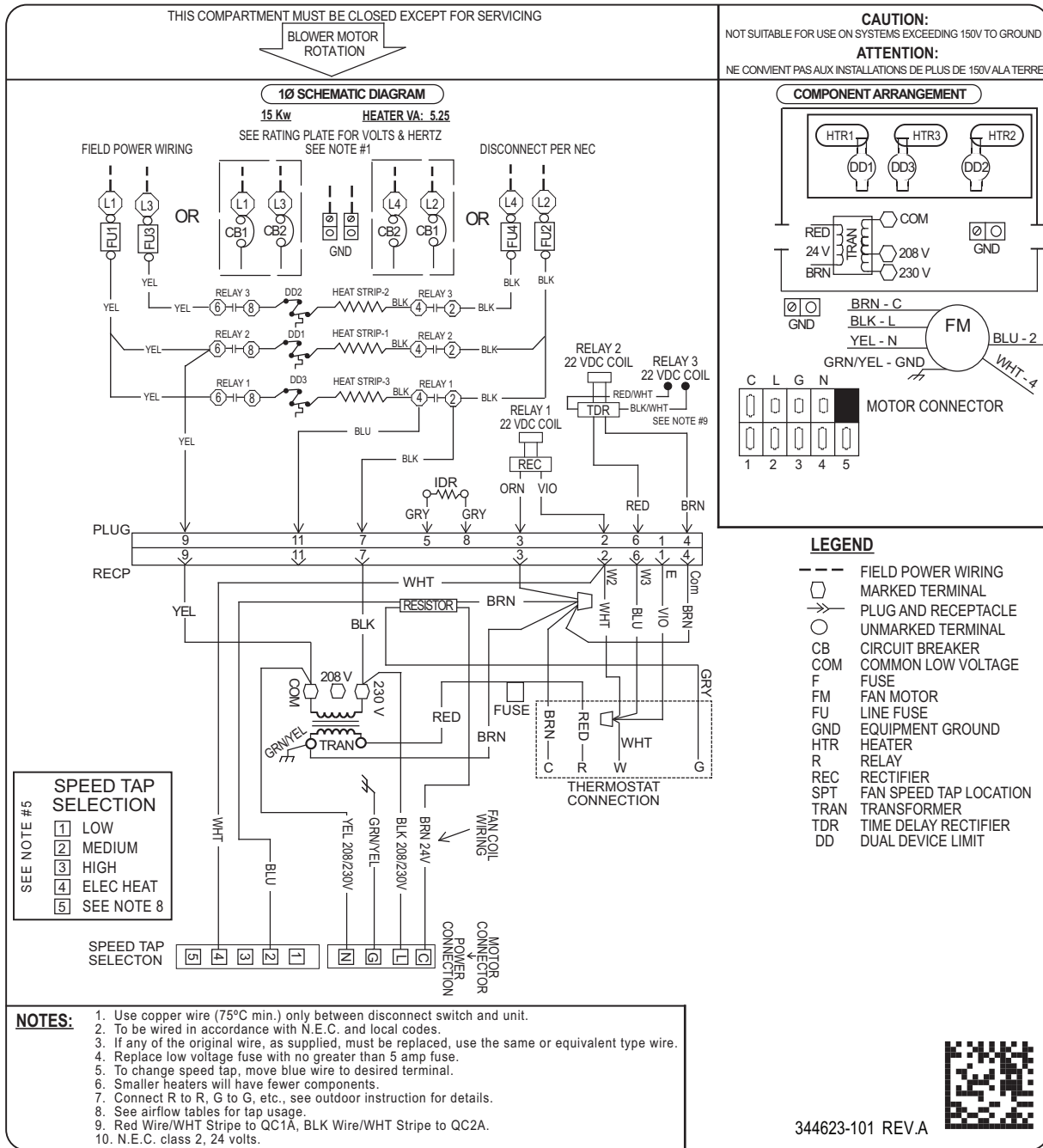
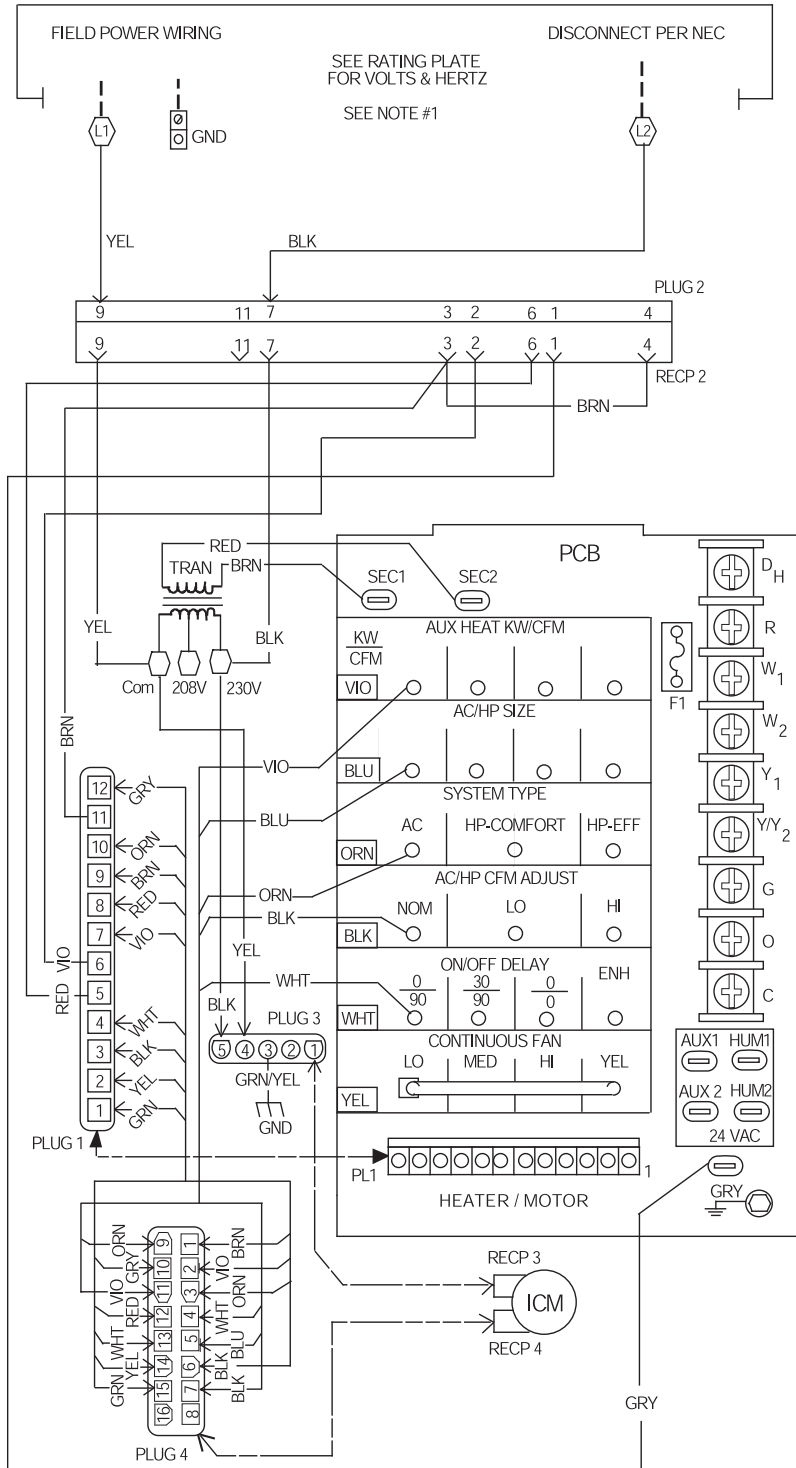

Fig. 12 – FB4C, FX4D - Heater MKFCEH1501F15B

THIS COMPARTMENT MUST BE CLOSED EXCEPT FOR SERVICING

BLOWER MOTOR ROTATION

COOLING ONLY SCHEMATIC DIAGRAM



LEGEND

- FIELD POWER WIRING
- ⊖ MARKED TERMINAL
- PLUG AND RECEPTACLE
- COM COMMON
- F1 LOW VOLTAGE FUSE
- GND EQUIPMENT GROUND
- ICM FAN MOTOR
- PCB PRINTED CIRCUIT BOARD
- RECP RECEPTACLE
- TRAN TRANSFORMER

COMPONENT ARRANGEMENT

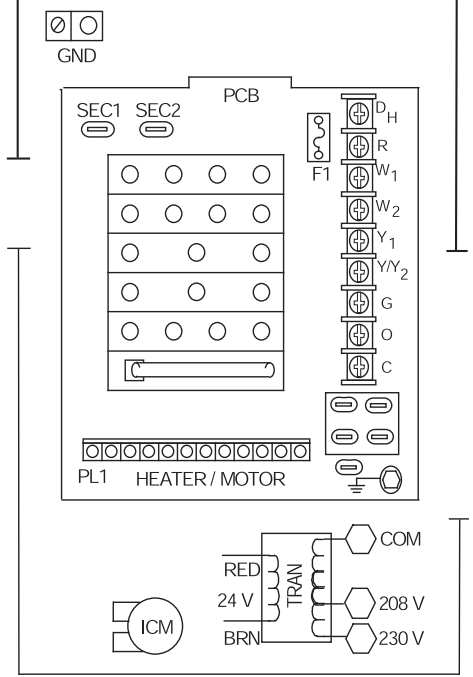

NOTES:

1. USE COPPER WIRE (75°C MIN) ONLY BETWEEN DISCONNECT SWITCH AND UNIT.
2. TO BE WIRED IN ACCORDANCE WITH N.E.C. AND LOCAL CODES.
3. TRANSFORMER PRIMARY LEADS, BLUE 208V, RED 230V.
4. IF ANY OF THE ORIGINAL WIRE, AS SUPPLIED, MUST BE REPLACED, USE THE SAME OR EQUIVALENT TYPE WIRE.
5. REPLACE LOW VOLTAGE FUSE WITH NO GREATER THAN 5 AMP FUSE.
7. USE 60 AMP CLASS K FUSES ONLY, FOR REPLACEMENT.
8. CONNECT R TO R, G TO G, ETC., SEE OUTDOOR INSTRUCTION FOR DETAILS.

326014-101 REV. D

Fig. 13 – FV4C with Cooling Only Control

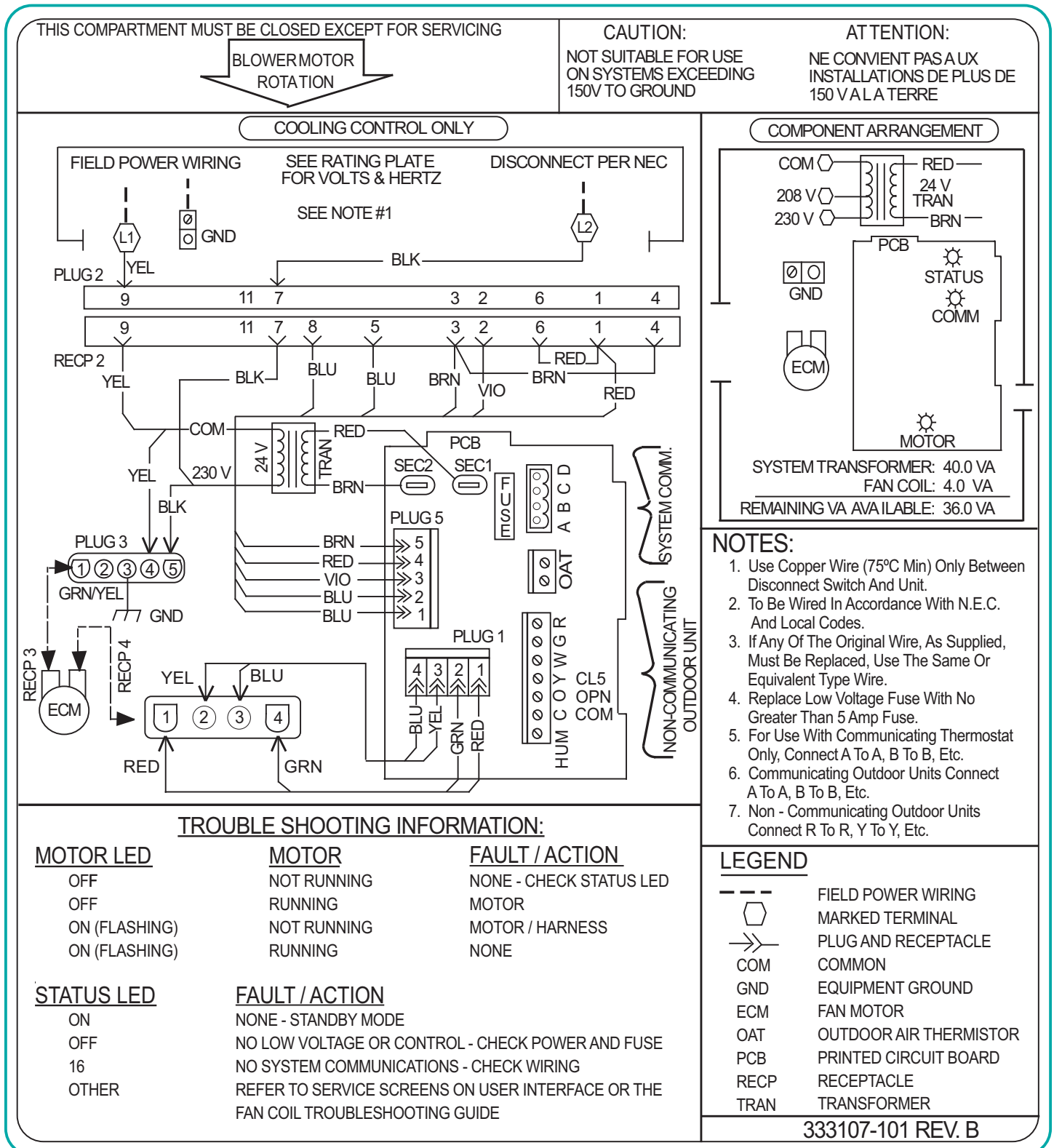

Fig. 14 – FE4A / FE5A with Cooling Only Control

A12363

THIS COMPARTMENT MUST BE CLOSED EXCEPT FOR SERVICING

BLOWER MOTOR ROTATION

COOLING CONTROL ONLY

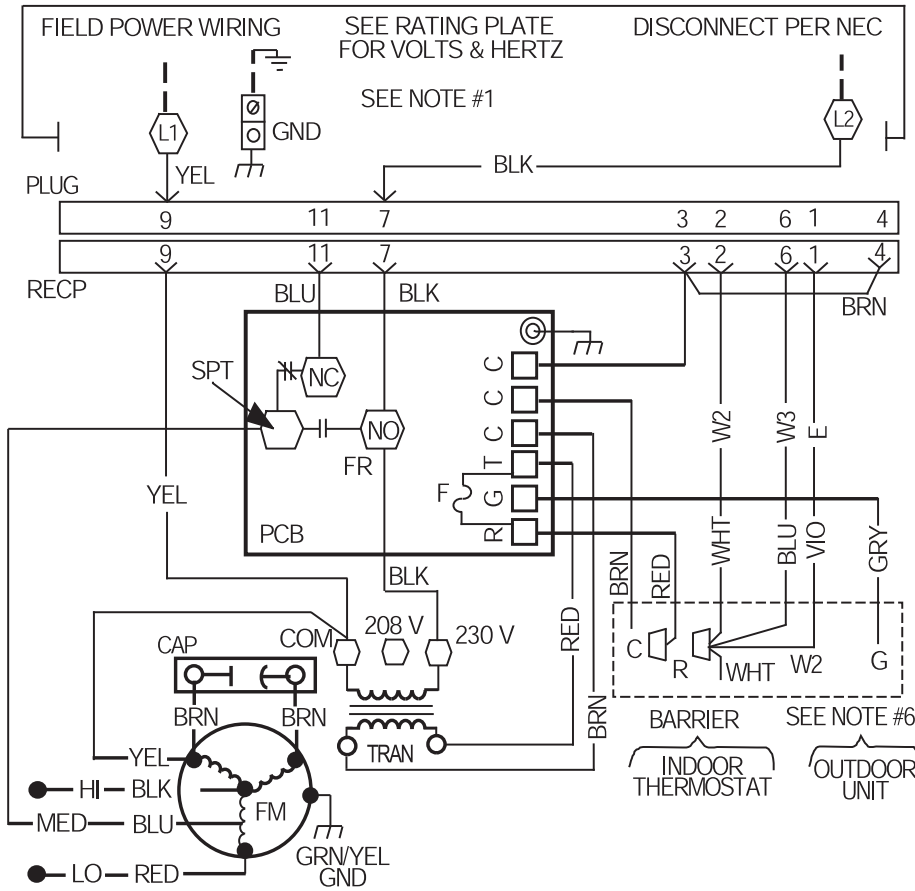

COMPONENT ARRANGEMENT

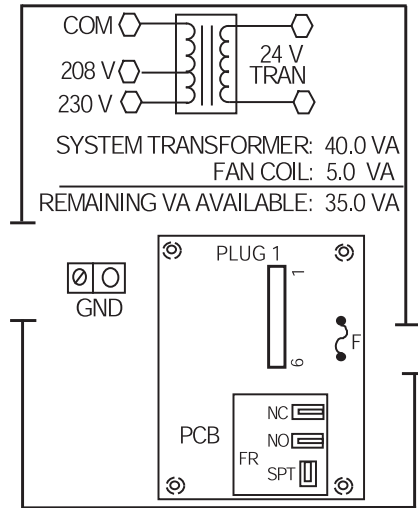

SEE NOTE #5

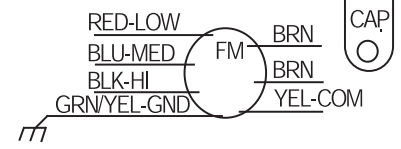

FAN MOTOR THERMALLY PROTECTED

LEGEND

- CAP CAPACITOR
- COM COMMON
- F LOW VOLTAGE FUSE
- FR PCB FAN RELAY
- FM FAN MOTOR
- GND EQUIPMENT GROUND
- PCB PRINTED CIRCUIT BOARD
- RECP RECEPTACLE
- SPT FAN SPEED TAP LOCATION
- TRAN TRANSFORMER

- UNMARKED TERMINAL
- FIELD POWER WIRING
- MARKED TERMINAL
- PLUG AND RECEPTACLE

328964-101 REV. A

Minimum Motor Speed Tap Selection For Electric Heater

MODEL SIZE	HEATER SIZE KW						
	3,5,8	9	10	15	18	20	24, 30
18	MED*	----	HI	----	---	----	----
24	MED‡	----	MED‡	MED‡	----	---	----
30	----	----	LO	LO	----	MED*	---
36, 42, 48, 60	----	LO	LO	LO	LO	LO	LO
70	----	MED	MED	MED	MED	MED	MED

* - MED speed on 3 speed motors and HI speed on 2 speed motors.
 ‡ - MED speed on 3 speed motors and LO speed on 2 speed motors.

NOTES

1. Use Copper Wire (75°C Min) Only Between Disconnect Switch And Unit.
2. To Be Wired In Accordance With NEC And Local Codes.
3. If Any Of The Original Wire, As Supplied, Must Be Replaced, Use The Same Or Equivalent Type Wire.
4. Replace Low Voltage Fuse With No Greater Than 5 Amp Fuse.
5. (3) Speed Motor Shown Optional (2) Speed Motor Uses HI (BLK) And LOW (BLUE or RED).
6. Connect R To R, G To G, Etc. See Outdoor Instruction For Details.

Fig. 15 – FH4C / FY5B / PF4MNA with Cooling Only Control

a07027

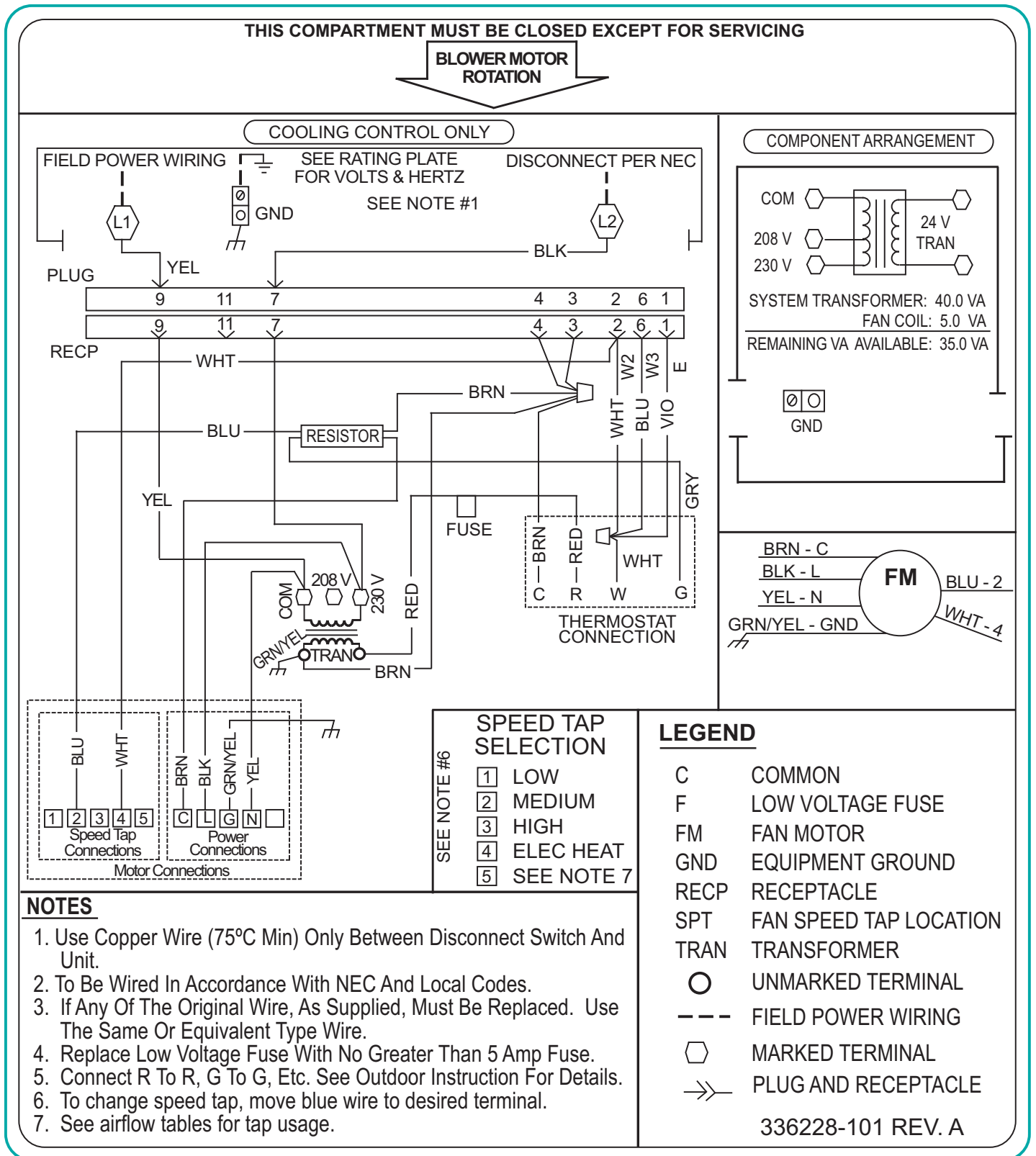

Fig. 16 – FB4C / FX4D / PF4MNP (RBC) / PF4MNA/B with Cooling Only Control

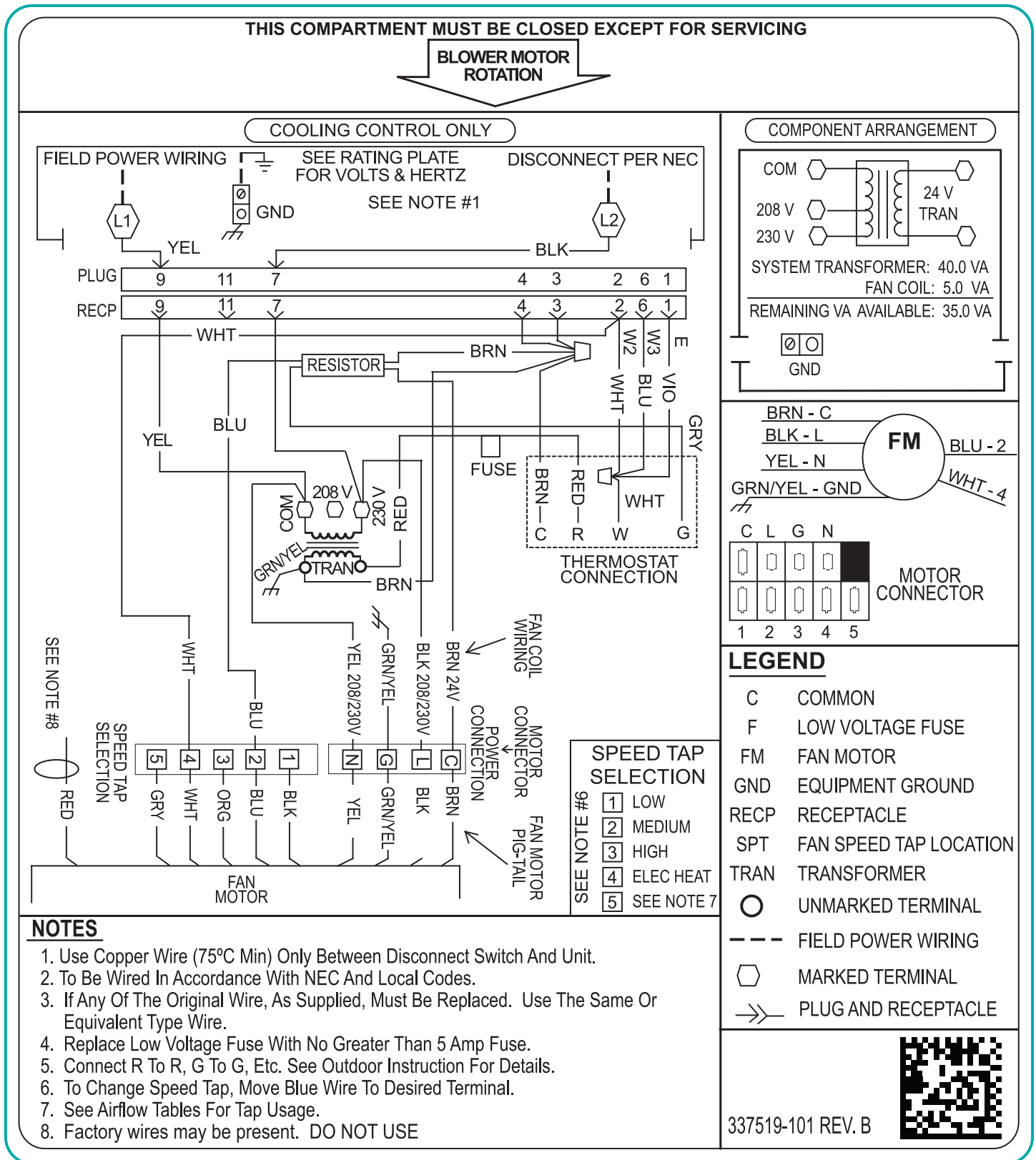

Fig. 17 – FB4C / FX4D / PF4MNP (BOM) with Cooling Only Control

A12365

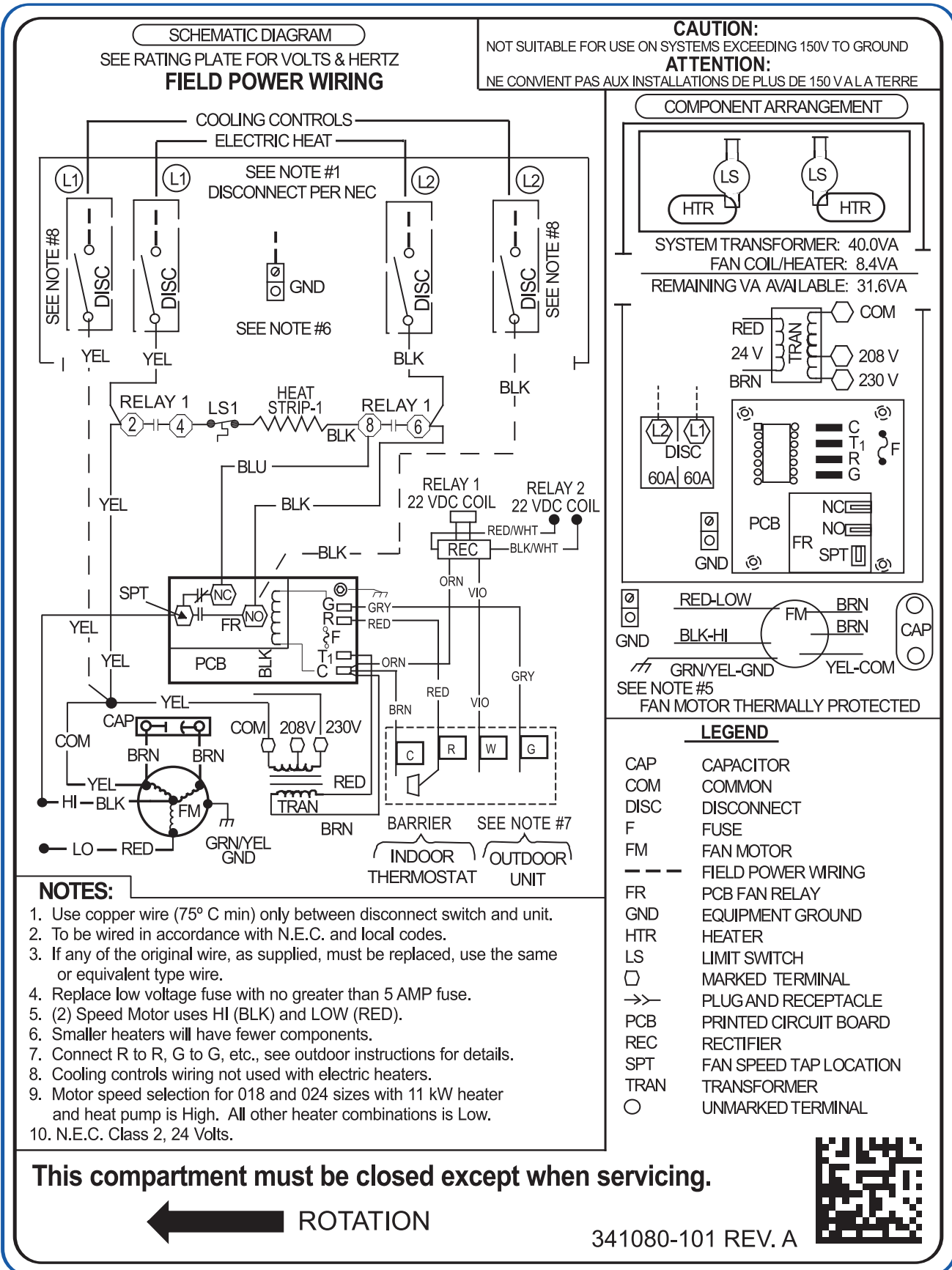

Fig. 18 – FF1E - Heater KFDEH0801D05A

A150114

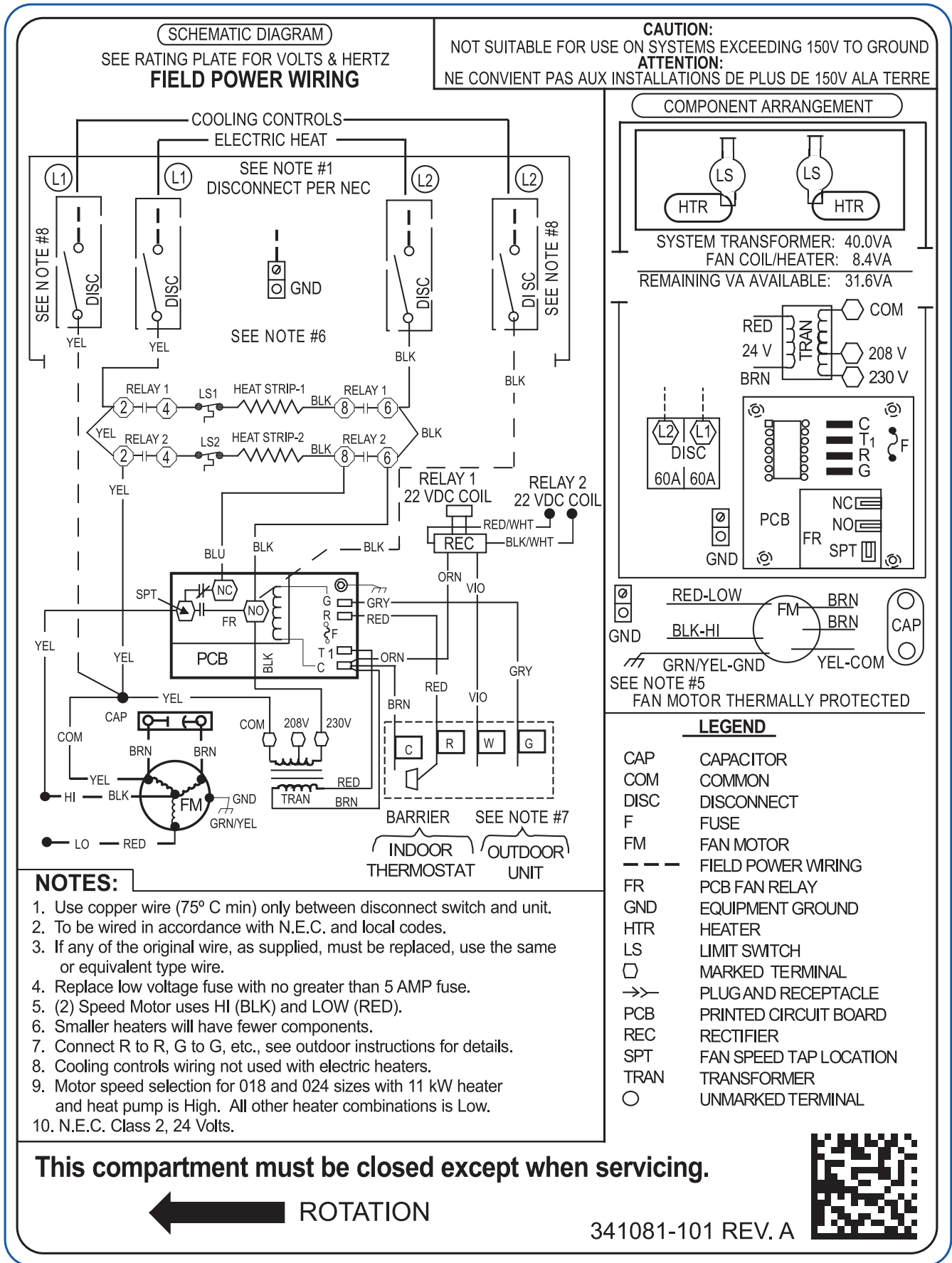

Fig. 19 – FF1E - Heaters KFDEH0901D75A / KFDEH1001D11A

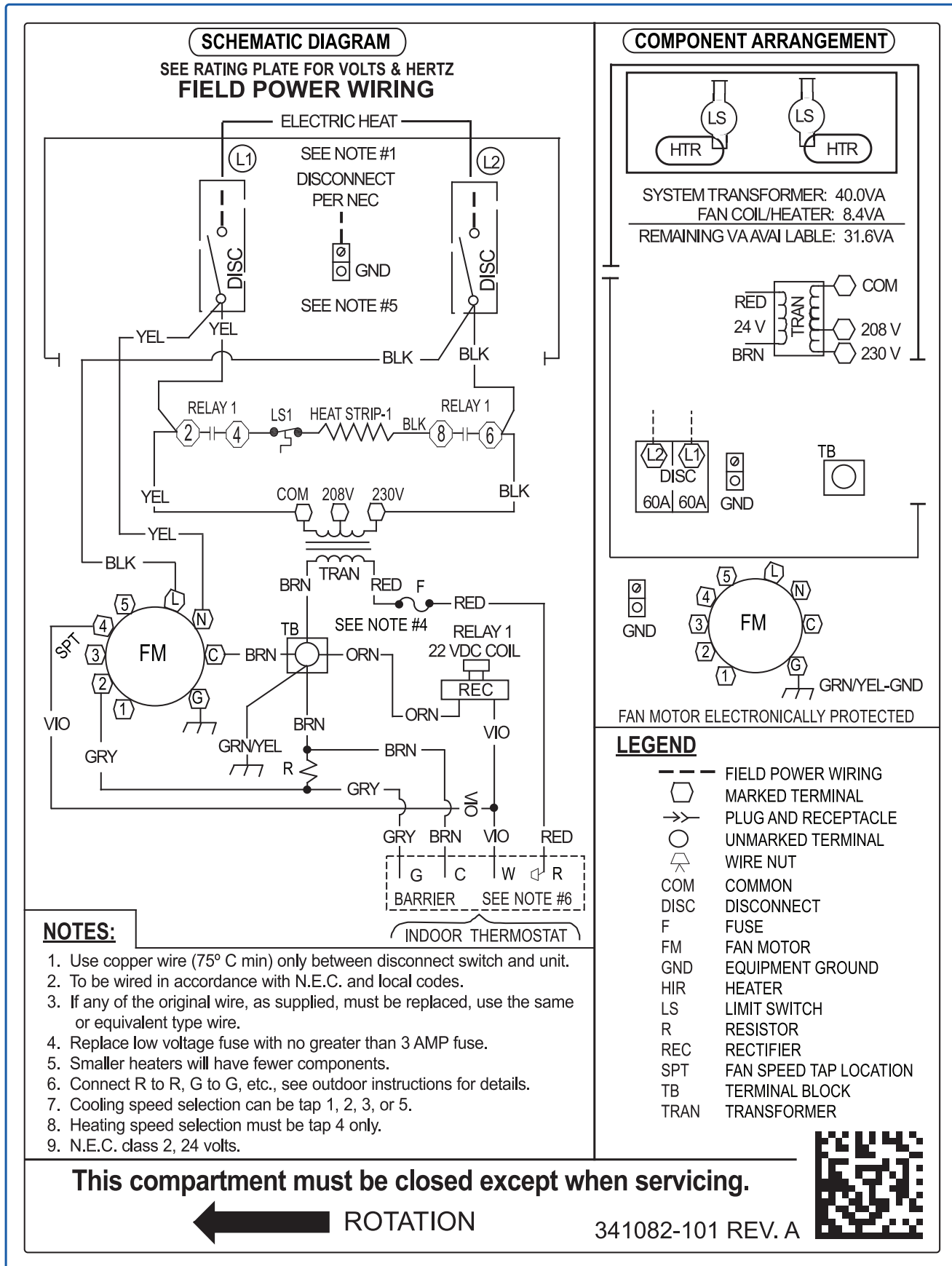

Fig. 20 – FF1E - Heater KFEEH0101D05A

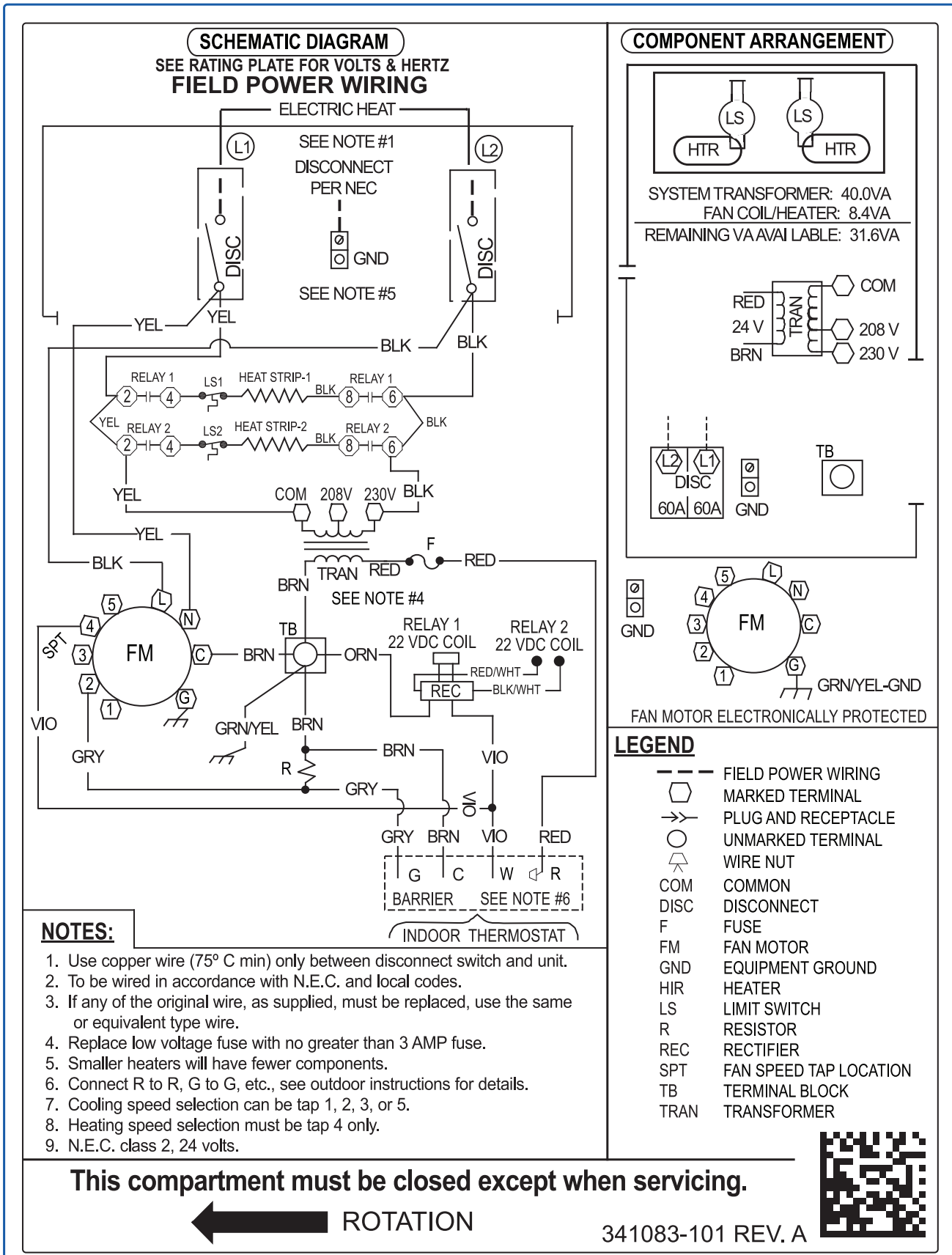

Fig. 21 – FF1E - Heaters KFEH0201D75A / KFEH0301D11A

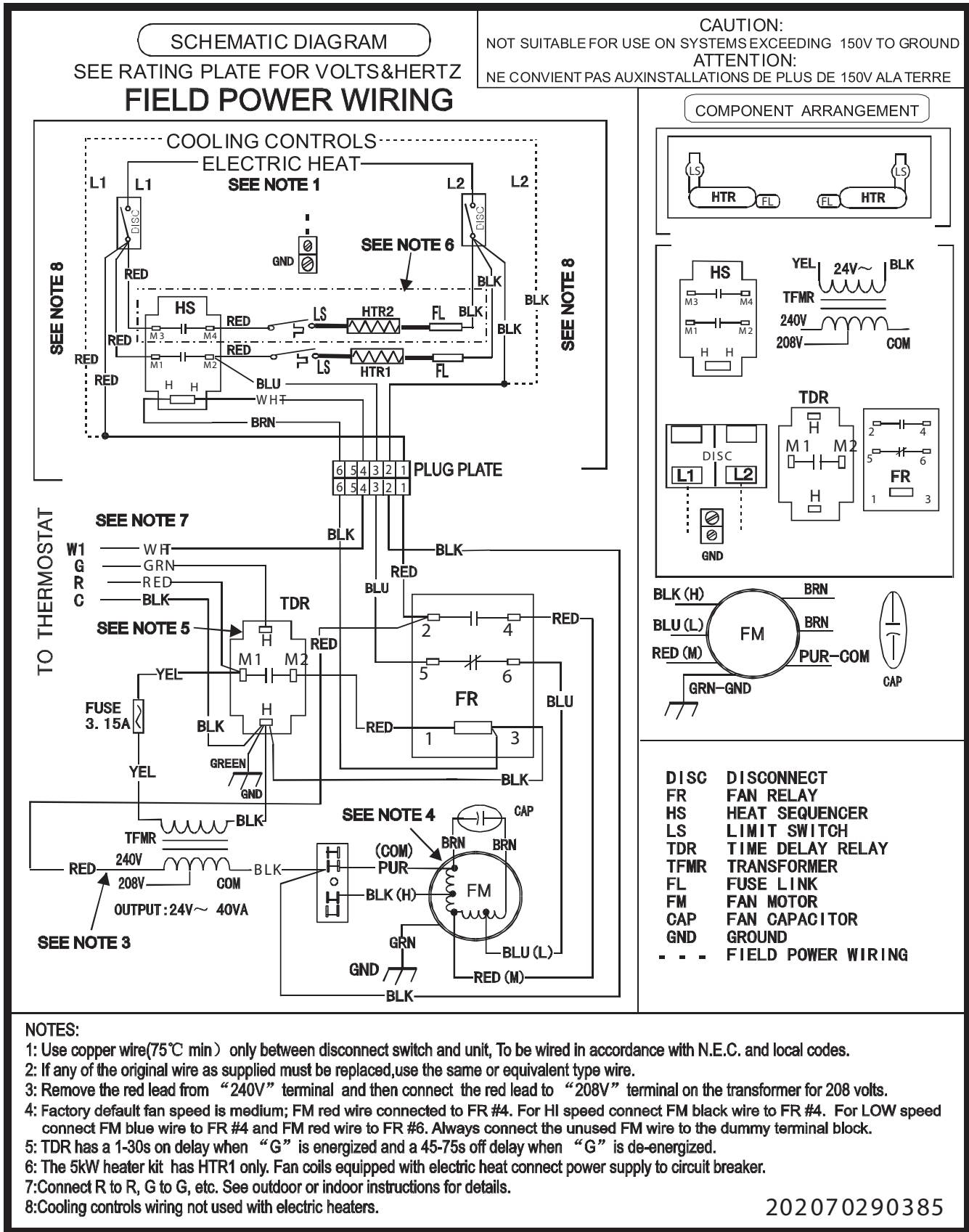

Fig. 22 – FFMANP(018,024,030,036 and EHK2 Electric Heaters with Sequencers

A13131

NOTE: Representative for FFMANP(018,024,030,036) prior to serial number date code 1715V

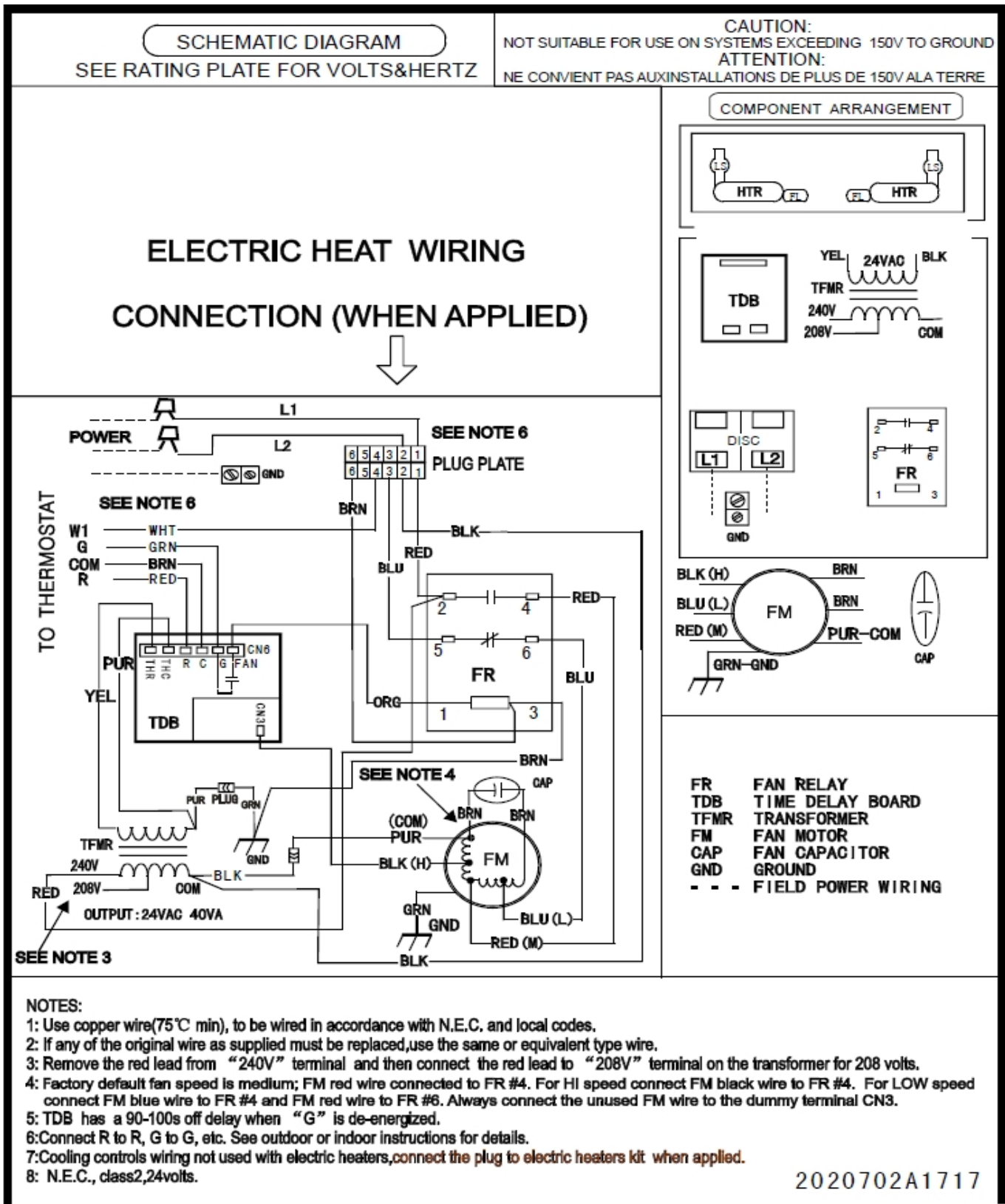

Fig. 23 – FFMANP(018,024,030,036 with PCB Time Delay

A150153

NOTE: Representative for FFMANP(018,024,030,036) serial number date code 1715V and later.

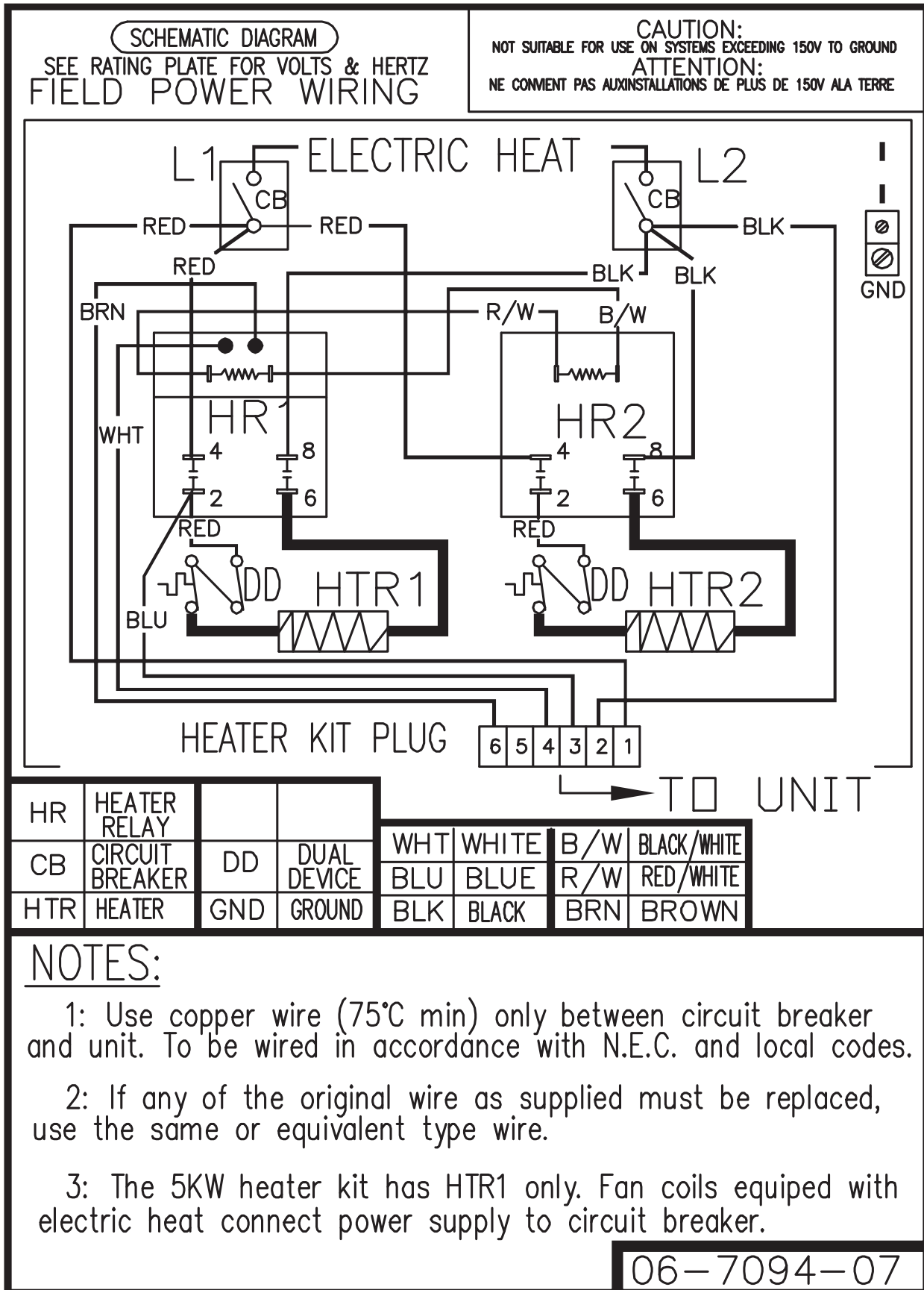

Fig. 24 – EHK2 With Heater Relays

A190017

SCHEMATIC DIAGRAM

SEE RATING PLATE FOR VOLTS&HERTZ
FIELD POWER WIRING

CAUTION:
NOT SUITABLE FOR USE ON SYSTEMS EXCEEDING 150V TO GROUND
ATTENTION:
NE CONVIENT PAS AUX INSTALLATIONS DE PLUS DE 150V ALA TERRE

CLASS 2
THERMOSTAT
CONNECTIONS

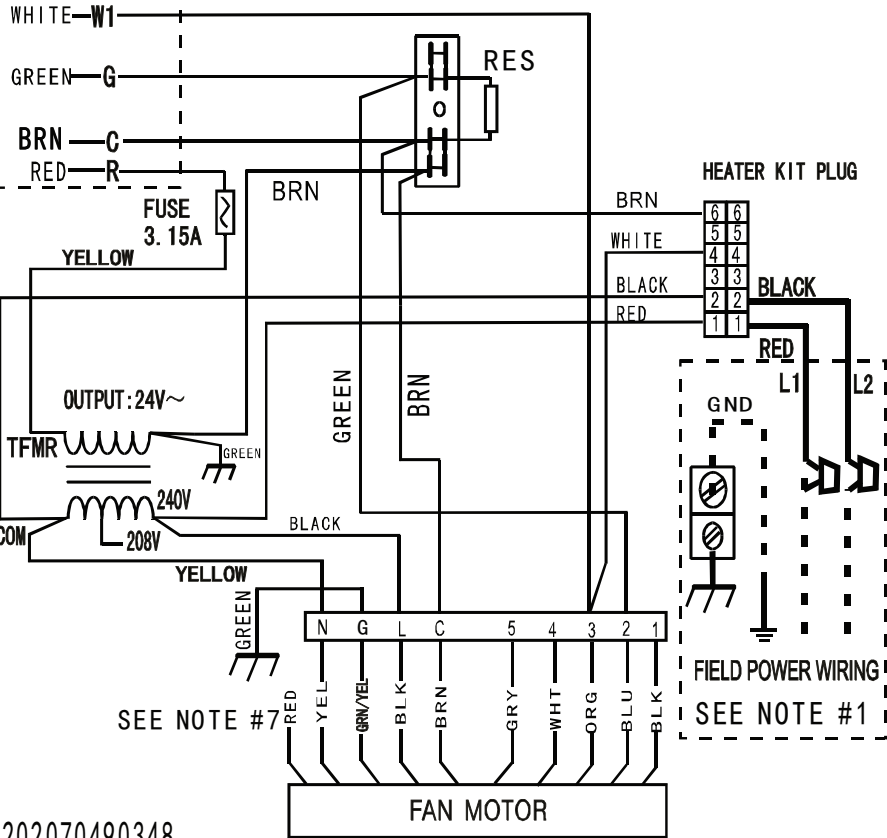

COMPONENT ARRANGEMENT

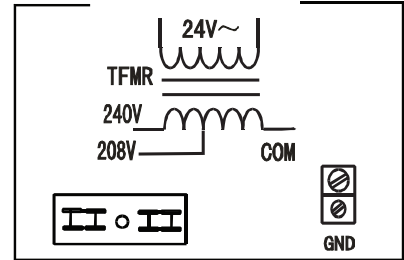

SPEED TAP SELECTION

- 1 LOW
- 2 MEDIUM LOW
- 3 MEDIUM
- 4 MEDIUM HIGH
- 5 HIGH

SEE NOTE #5, #6 & #8.

202070490348

NOTES:

- 1: Use Copper Wire (75°C Min) Only Between Disconnect Swich And Unit .
- 2: To Be Wired In Accordance With NEC And Local Codes.
- 3: If Any Of The Original Wire ,As Supplied, Must Be Replaced. Use The Same Or Equivalent Type Wire.
- 4: Connect R To R, G To G, Etc. See Outdoor Instruction For Details.
- 5: To Change Speed Tap, Move Green Wire Desired Terminal.
- 6: See Airflow Tables For Tap Usage.
- 7: Factory Wires May Be Present, DO NOT USE.
- 8: Taps 2 & 4 Have a 90s Delay Off, Taps 1, 3 & 5 are 30s.

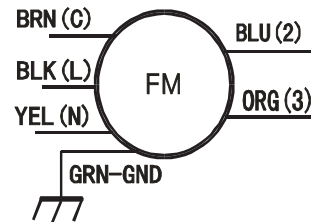

TFMR TRANSFORMER
FM FAN MOTOR
GND GROUND
RES RESISTOR
- - - FIELD POWER WIRING

Fig. 25 – FFMANP(019, 031)

A14323

SCHEMATIC DIAGRAM

SEE RATING PLATE FOR VOLTS&HERTZ
FIELD POWER WIRING

CAUTION:
NOT SUITABLE FOR USE ON SYSTEMS EXCEEDING 150V TO GROUND
ATTENTION:
NE CONVIENT PAS AUX INSTALLATIONS DE PLUS DE 150V ALA TERRE

CLASS 2
THERMOSTAT
CONNECTIONS

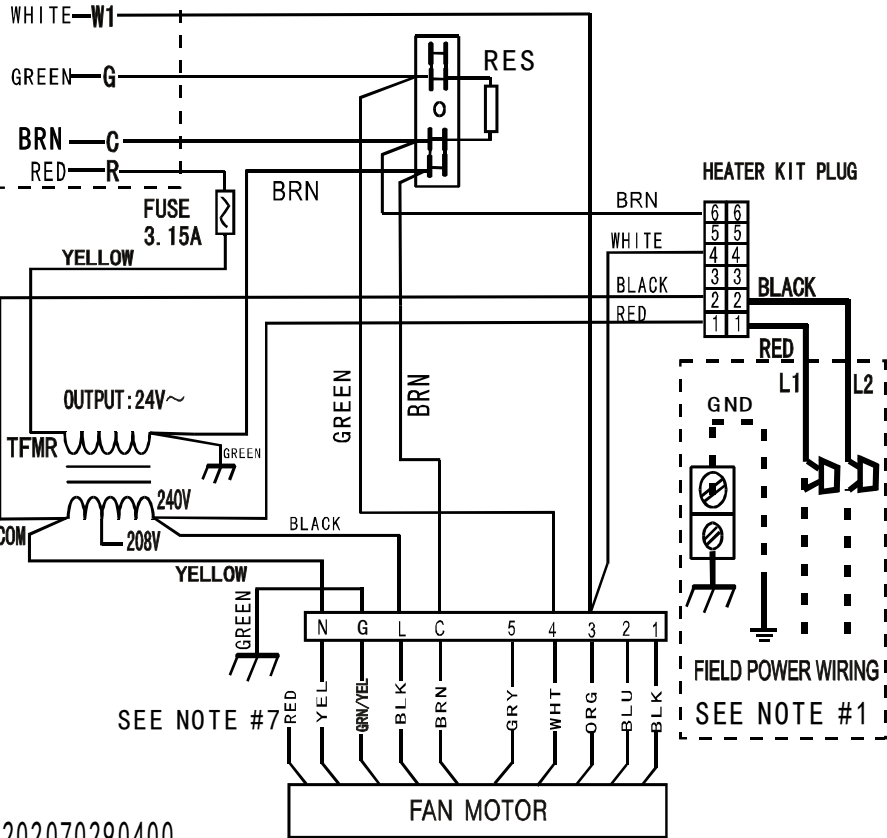

COMPONENT ARRANGEMENT

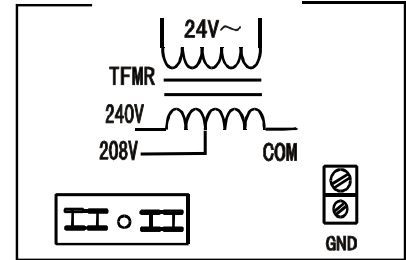

SPEED TAP SELECTION

- 1 LOW
- 2 MEDIUM LOW
- 3 MEDIUM
- 4 MEDIUM HIGH
- 5 HIGH

SEE NOTE #5, #6 & #8.

202070290400

NOTES:

- 1: Use Copper Wire (75°C Min) Only Between Disconnect Swich And Unit .
- 2: To Be Wired In Accordance With NEC And Local Codes.
- 3: If Any Of The Original Wire ,As Supplied, Must Be Replaced. Use The Same Or Equivalent Type Wire.
- 4: Connect R To R, G To G, Etc. See Outdoor Instruction For Details.
- 5: To Change Speed Tap, Move Green Wire Desired Terminal.
- 6: See Airflow Tables For Tap Usage.
- 7: Factory Wires May Be Present, DO NOT USE.
- 8: Taps 2 & 4 Have a 90s Delay Off, Taps 1, 3 & 5 are 30s.

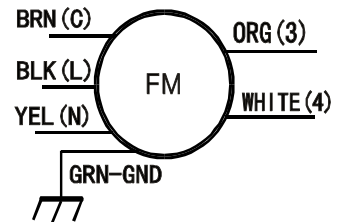

TFMR TRANSFORMER
FM FAN MOTOR
GND GROUND
RES RESISTOR
- - - FIELD POWER WIRING

Fig. 26 – FFMANP(025, 037)

A14324

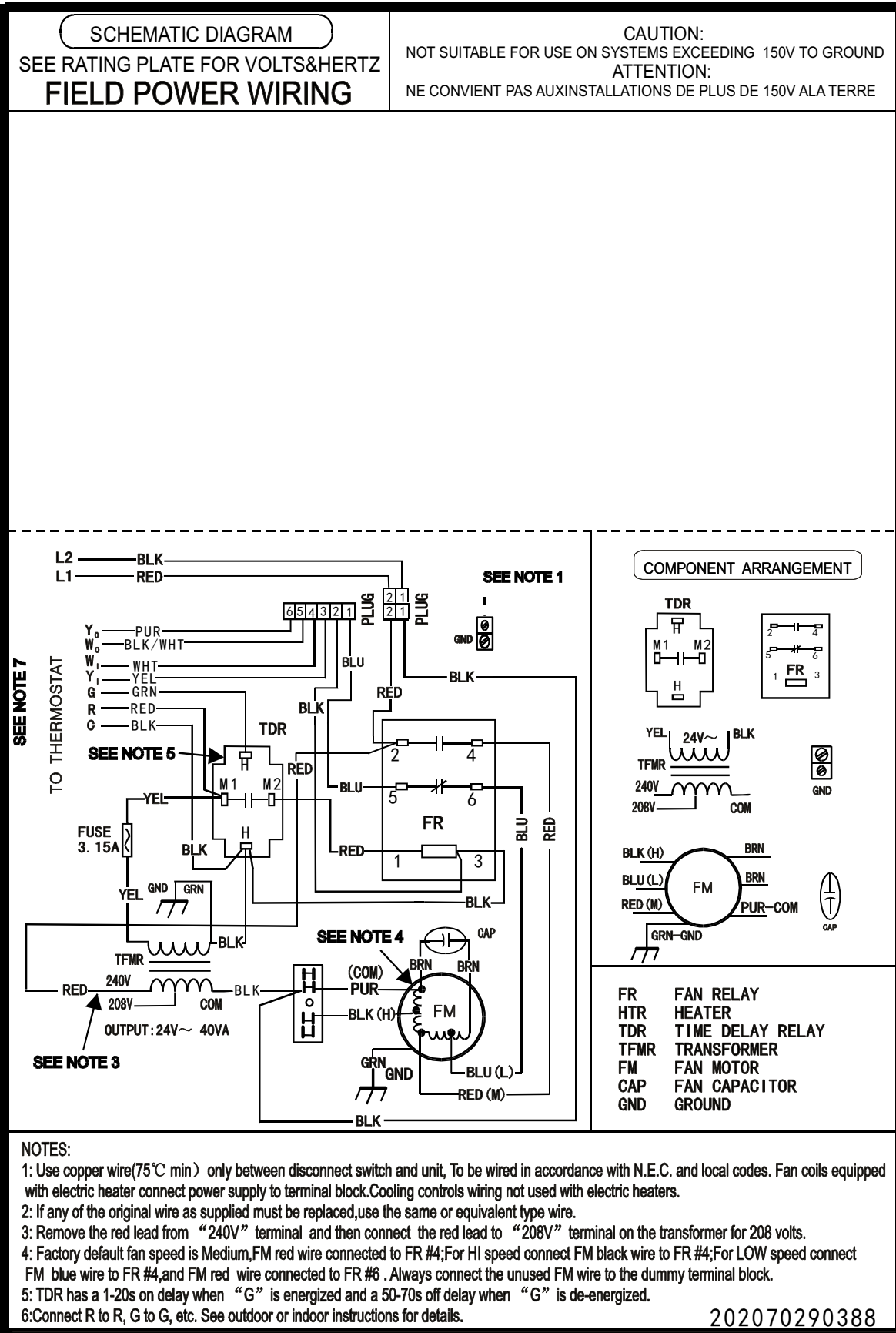

202070290388

Fig. 27 – FPM(A,B)N(U,C) with Time Delay Relay

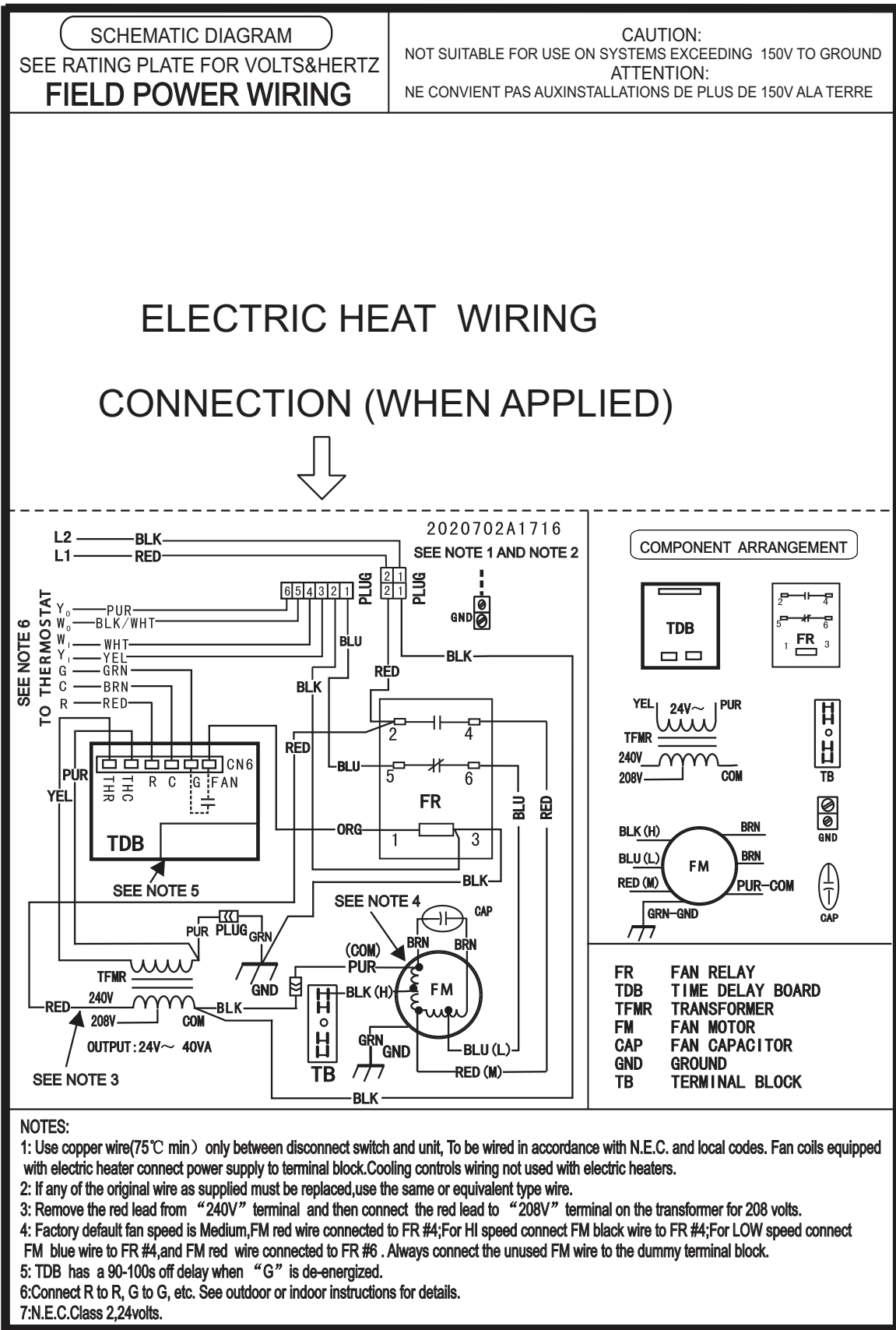

Fig. 28 – FPM(A,B)N(C,U) with Time Delay Board

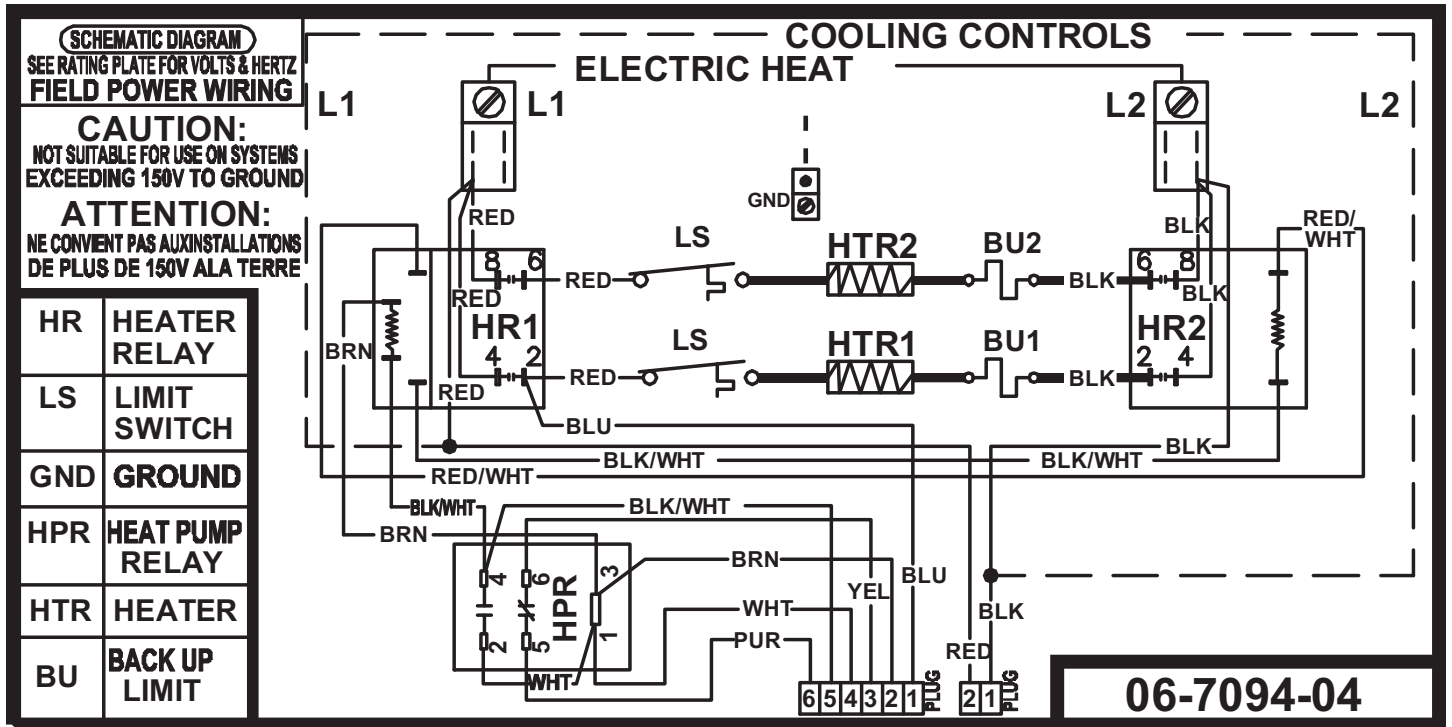

Fig. 29 – EHK3 With Heater Relays

A190016

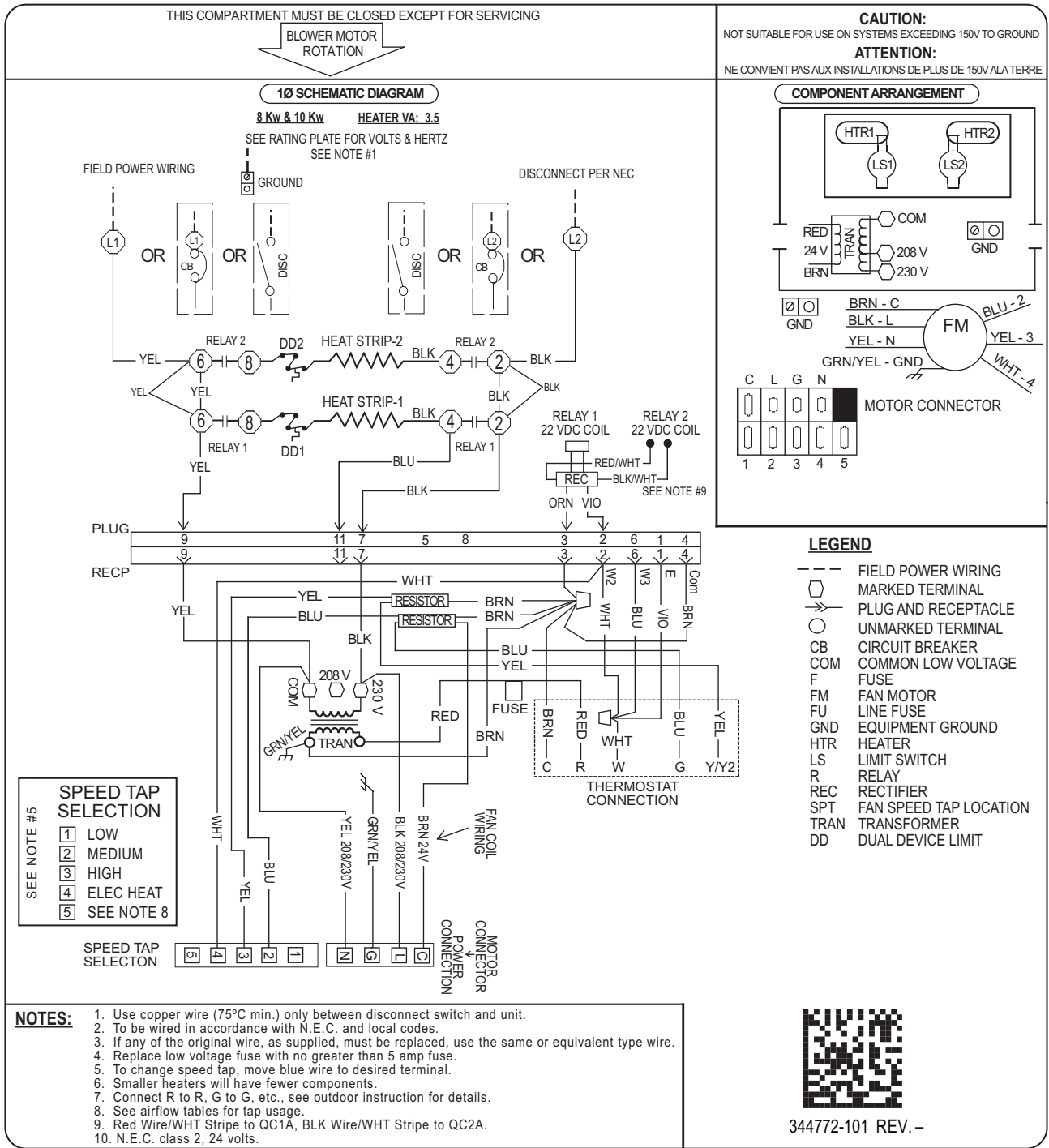

Fig. 30 – FZ4A, 3 & 4 Ton, with MKFCEH 0801N08B / 0901N10B Heater

A190020

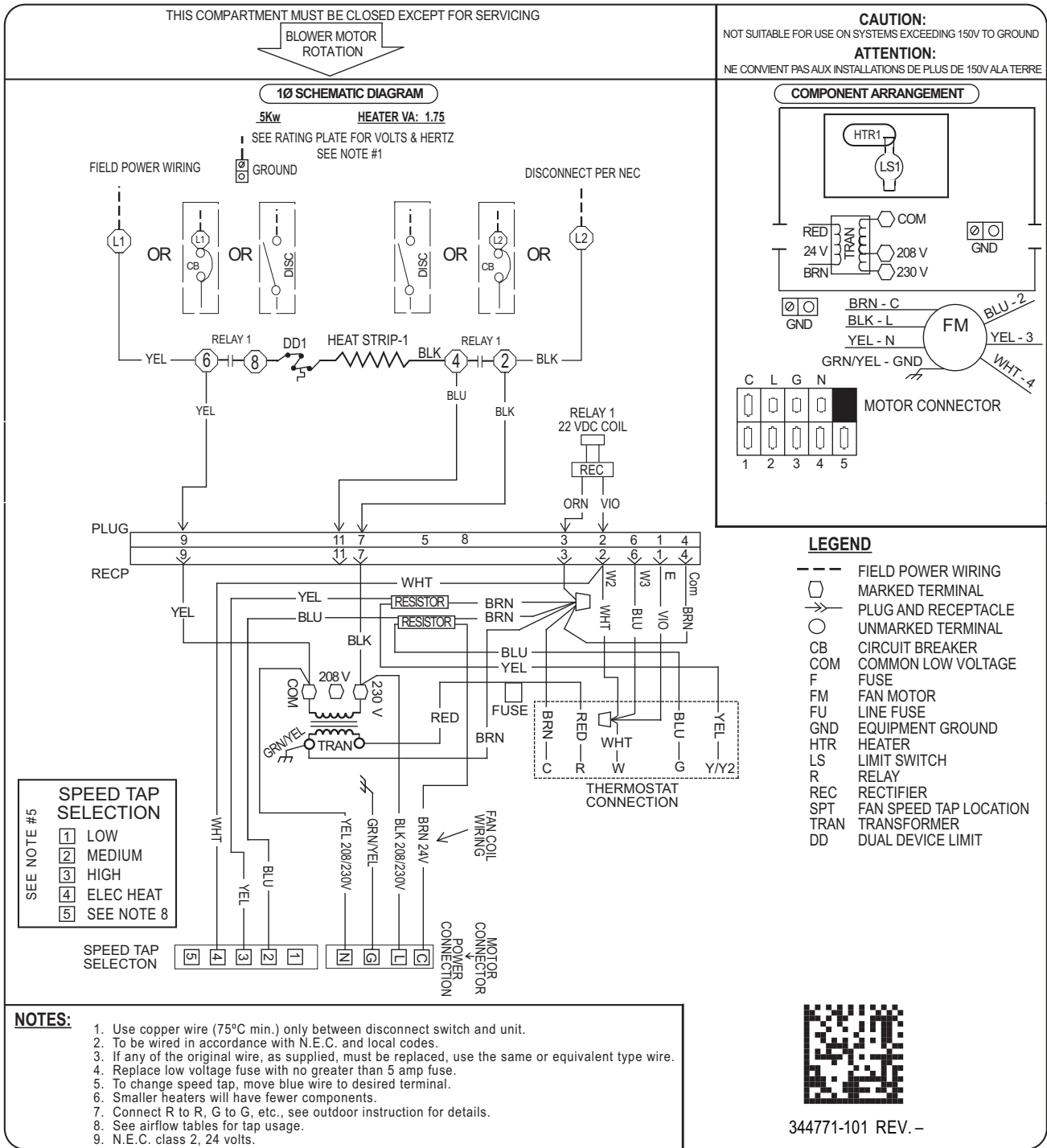

Fig. 32 – FZ4A, 2 Ton, with MKFCEH0501N05B Heater

A190019

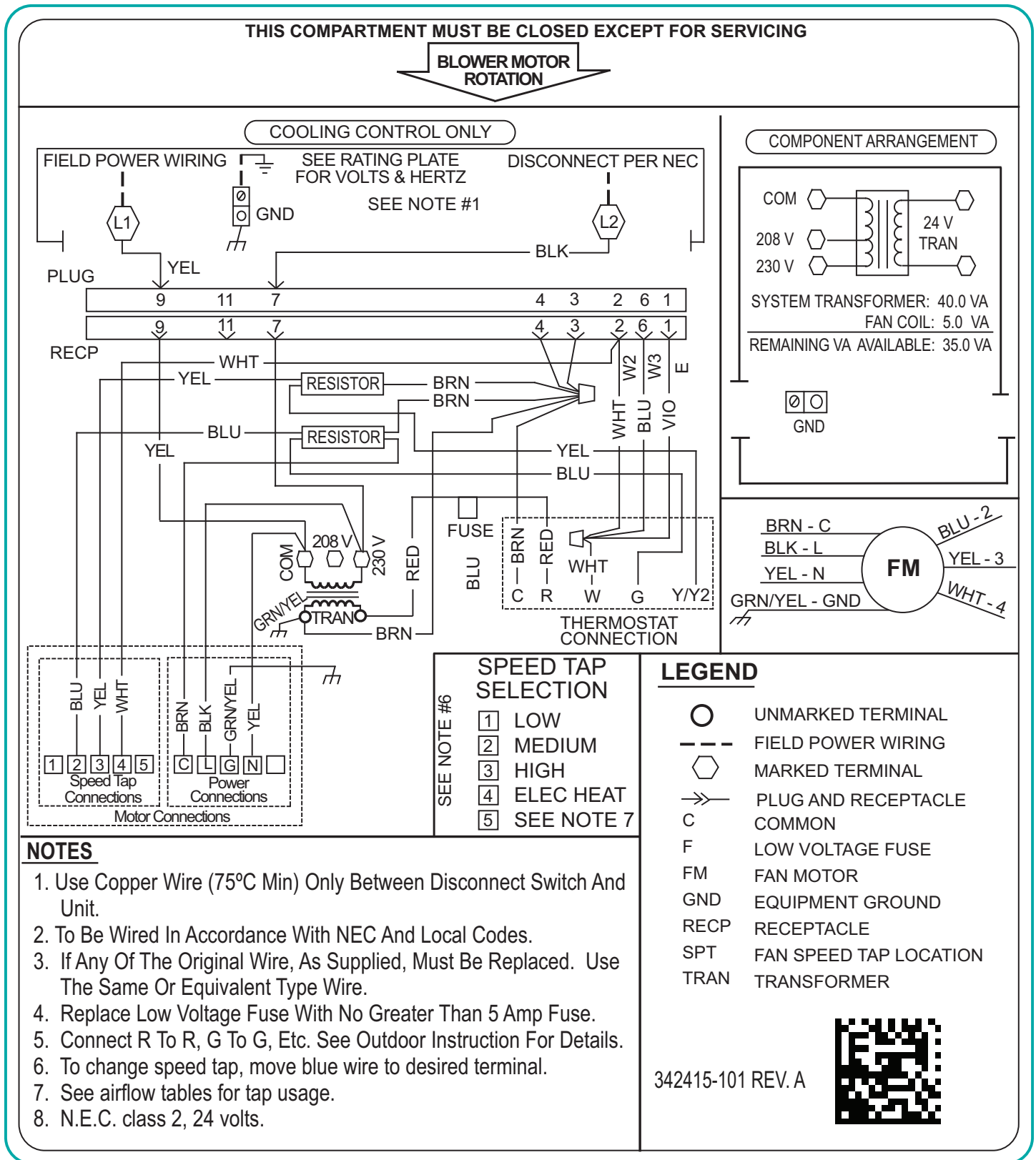

Fig. 33 – FZ4A

A160101

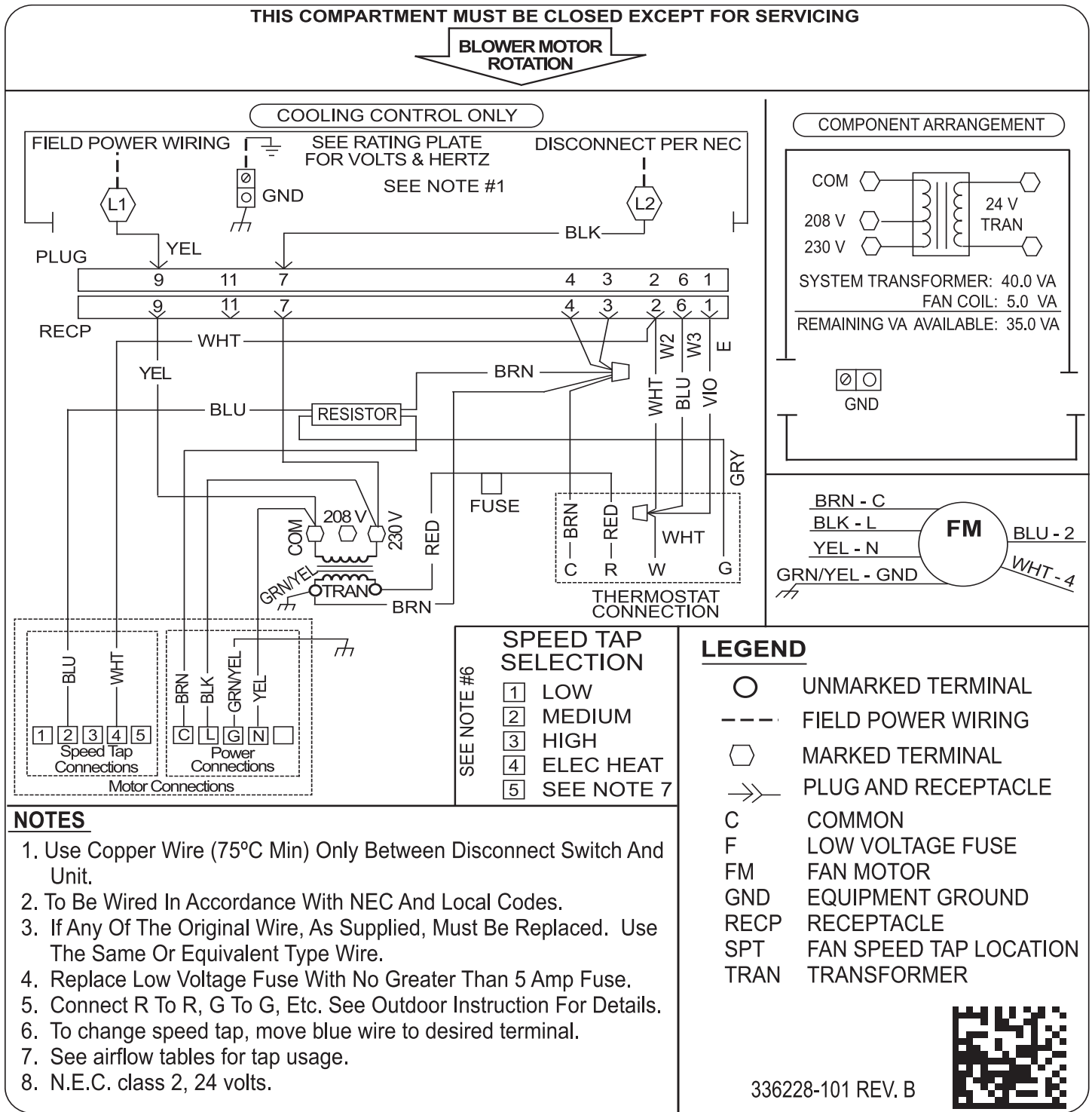

Fig. 34 – FB4(C/Q)SL

A170278

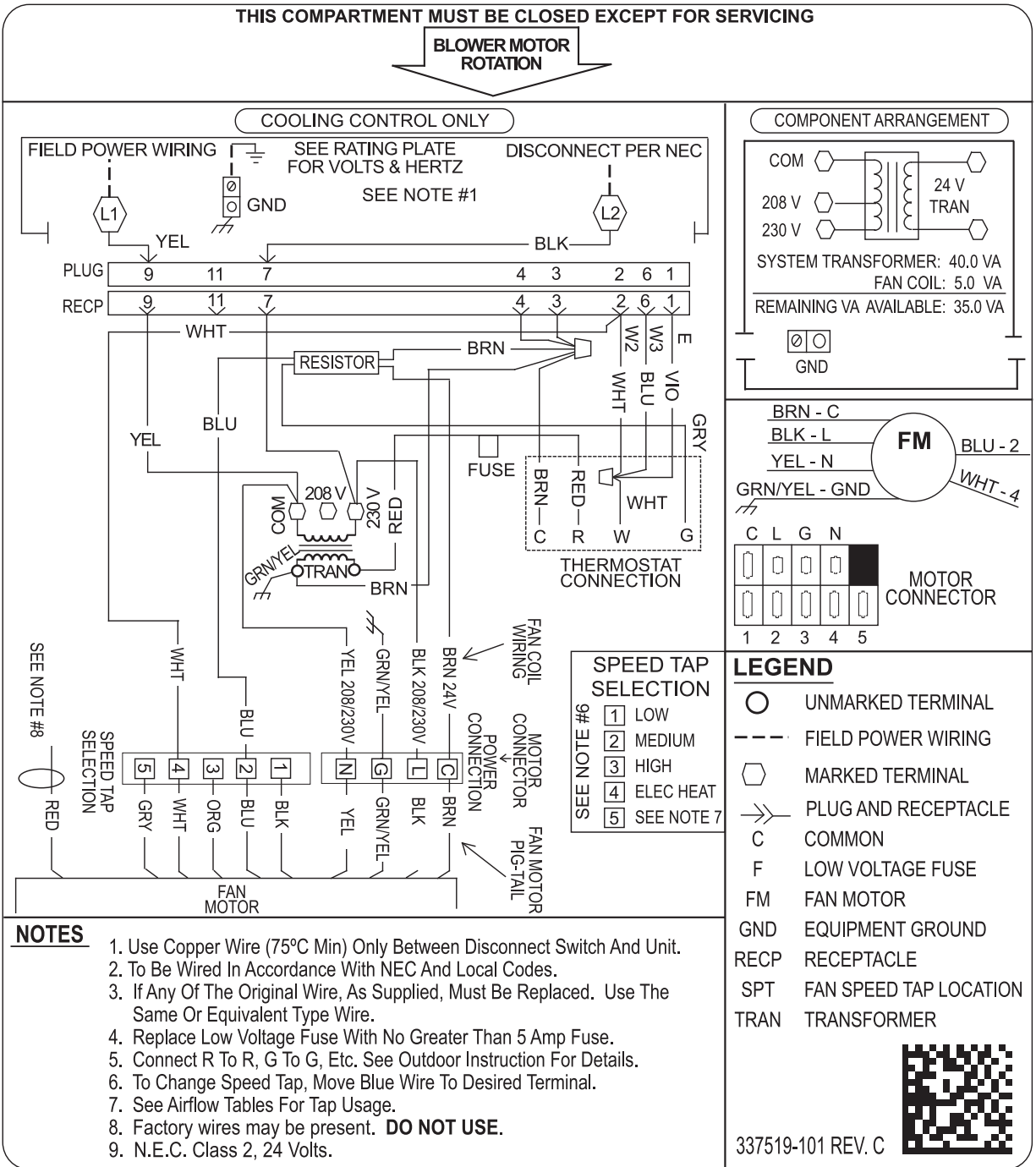

Fig. 35 – FB4(C/Q)SL

A170279

